



# NEWS IN CONSERVATION

INTERNATIONAL INSTITUTE FOR CONSERVATION OF HISTORIC AND ARTISTIC WORKS



How are endbands like bees? | Socratic dialogue for conservators | *Lost Leonardo* now playing



The International Institution for Conservation (IIC) launched a new full-color conservation newspaper *News in Conservation (NiC)* in 2007 and transitioned into a completely digital e-magazine in 2011. Published six times a year, *NiC* provides a platform for members of the conservation community to share the latest research, interviews, and reviews; to promote new events, products, and opportunities; and to call for papers, ideas, and involvement. *NiC* also provides updates from the IIC Council and Regional Groups. *NiC* continues to evolve to better fit the needs and interests of our increasingly global conservation profession.

## ACCESS YOUR *NiC*

Get connected! Download the most recent issue of *NiC* plus all past issues [here](#). To directly receive each new *NiC* issue, subscribe for FREE at the bottom of [this webpage](#)!

In addition to the traditional PDF version, *NiC* subscribers now have access to *NiC* using ISSUU, giving the magazine a modern, digital, page-turning format including extra content like videos, links, and more! Each issue will now contain BONUS CONTENT exclusively available to members, so renew your membership or [become an IIC Member today!](#)

## WRITE FOR *NiC*

To contribute news or a feature idea to *News in Conservation*, email *NiC* Editor Sharra Grow at: [news@iiconservation.org](mailto:news@iiconservation.org). Submission guidelines and copyright information can be downloaded at the bottom of [this webpage](#).

## ADVERTISE IN *NiC*

*NiC* is sent directly to nearly 3,000 specialist subscribers across the world and is available on IIC social media to over 46,000 followers. For more information on advert sizes, deadlines, rates, and packages, please get in touch with *NiC* Editor Sharra Grow at: [news@iiconservation.org](mailto:news@iiconservation.org). Our Rate Card and Media Kit are available for download [here](#).

**Cover image:** 10-metre-high projection screen being suspended from the roof in Art Gallery of New South Wales 19<sup>th</sup> century "old court" 2020, image by Asti Sherring (story on p. 12). **Inside cover image:** Sampling of the mural painting on the wall of Colletta Swimming Pool (various artists, 2011). Courtesy of the University of Turin and La Venaria Reale Conservation-Restoration Center (story on p. 49).

*News in Conservation* is published by  
**The International Institute for Conservation of Historic and Artistic Works**  
 3 Birdcage Walk  
 London SW1H 3JJ  
 Tel: +44 (0)20 7799 5500  
[www.iiconservation.org](http://www.iiconservation.org)  
 ISSN 1995-2635

**NiC Contributing Staff**  
**Sharra Grow**, Editor in Chief  
[news@iiconservation.org](mailto:news@iiconservation.org)

**Ellie Sweetnam**, Fellowship and Membership Programme Manager  
[Ellie.Sweetnam@iiconservation.org](mailto:Ellie.Sweetnam@iiconservation.org)

**Alexandra Taylor**, Book Reviews Coordinator  
[alexandra.taylor2@outlook.com](mailto:alexandra.taylor2@outlook.com)

**Marina Herriges**, Associate Editor for Environmental Sustainability  
[marina.herriges@gmail.com](mailto:marina.herriges@gmail.com)

**Kate Stonor**, Web News Editor  
[kate@tsrimaging.com](mailto:kate@tsrimaging.com)

**Kate Smith**, Digital Engagement Editor  
[communications@iiconservation.org](mailto:communications@iiconservation.org)

### Editorial Submissions

Deadline for December-January 2022 issue submissions is 1 November 2021. Submit to [news@iiconservation.org](mailto:news@iiconservation.org). Email request for submission guidelines.

### Advertising

Deadline for December-January 2022 issue materials is 15 November 2021. Submit to [news@iiconservation.org](mailto:news@iiconservation.org). Email request for rate card and submission guidelines.

**Disclaimer:** Whilst every effort is made to ensure the accuracy, sufficiency and completeness of information contained in this publication, neither the IIC nor its Editors shall be liable to any party for any loss and/or damage arising from (i) any errors or omissions in such information and (ii) the use of, or reliance on, any method, product, instructions or ideas in this publication, in each case to the fullest extent permitted by law. The opinions stated in individual articles belong to the author(s) and do not necessarily reflect those of the IIC, its officers or Council. Information contained in this publication is strictly for educational purposes and aims to provide helpful information on the topics discussed. Any information relating to a product, method or treatment is not meant to be, nor should it be taken to be, an endorsement of such product, method or treatment.

© The International Institute for Conservation of Historic and Artistic Works, 2021

# CONTENTS

- 4 THE PRESIDENT'S DESK
- 5 FROM THE EXECUTIVE DIRECTOR | EDITOR'S SOUNDING BOARD
- 6 NEWS IN BRIEF  
 Conservation of the Hartwell Memorial Window  
*The Lost Leonardo* now playing!  
 European Days of Conservation-Restoration (ECCO)  
 IIC S-G Jane Henderson and Stephen Clare MBE awarded Plowden Medal
- 12 FEATURE ARTICLES  
*Digital Disruption and Divergent Conservation: opportunities and challenges relating to the development of time-based art conservation*, Asti Sharring  
  
*Of Endbands and Bees: or of the troubles and limits of terminology in bookbinding descriptions*, Georgios Boudalis  
  
*Robin Hodgson: Looking up in lockdown*, Christopher Lawrence
- 30 IIC NEWS  
 Participate with IIC at COP26  
 Emerging Conservator Zoom Talk: PhD Project Proposals (8 December 2021)  
 Featured Job Listings  
 Fellowship Corner & Meet our Trustees
- 36 STUDENT & EMERGING CONSERVATOR  
 2021 IIC-SECC, 14-16 October: Meet the Session Speakers
- 38 ENVIRONMENTAL SUSTAINABILITY  
*Sustainability: what we can learn from a holistic approach*, Marina Herriges  
  
*Our Collections Matter: enabling sustainability through collections and conservation*, Henry McGhie and José Luiz Pedersoli, Jr.  
  
 "Starter for Ten" Sustainability Guide now on IIC Community Platform
- 46 BOOK REVIEWS  
*The Renaissance Restored*, reviewed by Kimberly Frost
- 49 EVENT REVIEWS  
*Conservation of Art in Public Spaces (CAPuS) project and its outcomes*, Dr. Sagita Mirjam Sunara  
  
*Contextualizing decision-making models in contemporary art conservation*, Julia Betancor  
  
*Originality and Authenticity: A real Socratic dialogue*, Ellie Sweetnam
- 58 ANNOUNCEMENTS

## FROM THE PRESIDENT'S DESK

I was struck by a 38-year-old's recent comment identifying herself as part of the last generation that has any real power to mitigate the worst of the impact of climate change. This is the generation represented at [IIC's Student and Emerging Conservator Conference](#) taking place this month at the Nova School of Science and Technology in Lisbon.

With November comes the COP26 Climate Change Conference in Glasgow when this generation and those of us from earlier generations come together from around the world to see what stomach our leaders have for making the hard decisions to limit the planet's temperature rising past the critical 1.5° C above pre-industrial levels. Whatever the outcomes, it is clear that every part of society, every profession and indeed every individual can and will need to play a part in taking the required actions to achieve the necessary goals.

How is IIC representing the global conservation profession in these critical times? Firstly we want to truly represent all conservators whether or not they are members of IIC. So we are very pleased to have partnered with both ICOM-CC and ICCROM to establish a joint commitment to, in the words of the commitment, mobilise an **international coalition of leading sustainability and net zero initiatives with the aim of unlocking the potential in our sector to contribute to the global agenda and action on climate change.** I am grateful to my counterparts at ICOM-CC, Kate Seymour (Chair of the Directory Board), and at ICCROM, Webber Nodoro (Director General), for their active support in this commitment. Between our three organisations, we can truly say that the conservation profession is well represented.

Secondly, IIC has been selected in a highly competitive process to represent our field as one of the few exhibitors in the Green Zone of the two week COP26 conference. I want to particularly acknowledge the hard work of our Executive Director Sarah Stannage in achieving this. You will find elsewhere in this edition of *News in Conservation* the initiatives that we are taking as part of our involvement in COP26 including the 24-hour global Edit-a-Thon and the "Capturing Conservation on Film" project.

The great thing is that each and every one of us can genuinely feel we are represented there as an international body of conservation professionals, that we are part of COP26, directly part of the process of contributing to the global agenda for action on the climate crisis.

Whatever the outcome of Glasgow, we need to ensure we are playing our part in mitigating the impact of climate change and adapting where necessary. We know the devastating effects that climate change is causing to cultural heritage. As a passion profession, we are unified in being passionate about what we can do to preserve cultural heritage, both tangible and intangible, from loss. We recognise the principle of equity so strongly emphasised in the UN's 2021 Intergovernmental Panel on Climate Change (IPCC) that many of the impacts of warming beyond 1.5°C, and some potential impacts of mitigation actions, fall disproportionately on the poor and vulnerable.

As the 38-year-old that I began this column with recognised, and as quoted on the front page of the IPCC report, "As for the future, your task is not to foresee it, but to enable it." *"Pour ce qui est de l'avenir, il ne s'agit pas de le prévoir, mais de le rendre possible."* Antoine de Saint-Exupéry

IIC is committed to assisting conservators world-wide with action on climate change, and we look forward to sharing with you our initiatives to achieve this.

With my best wishes,

Julian Bickersteth  
*IIC President*



IIC President Julian Bickersteth delivering his column. Click above to watch or follow the link [HERE](#).

# MESSAGE FROM THE EXECUTIVE DIRECTOR

As we head into October, there are lots of opportunities coming up for you to get involved and take part in our programmes and events, including the next Student and Emerging Conservator Conference, [S&ECC Lisbon 2021](#) (14-16 October 2021) and Emerging Conservator Zoom Talk (8 December 2021).

We are also thrilled to have been selected to exhibit this November in the Green Zone at the international climate conference, COP26 in Glasgow. This is our opportunity as an international body for conservators and cultural heritage professionals to contribute to the global agenda on climate change. We know it is incumbent on all of us to adapt, innovate and pioneer change, and at IIC we intend to lead by example. Which is why IIC is committed to reaching net zero by 2030 and making sustainability inherent to everything we do—from our biennial Congress to our [leadership and mentoring programmes](#) aimed to support members to act with decisiveness, expertise and resilience to future challenges. Alongside our [COP26 IIC exhibition and film programme](#), showcasing all the wonderful media content sent to us by members, we are organising a 24-hour global Edit-a-Thon, [#IICEditsClimate](#), online and live from Glasgow, 10-11 November 2021. We hope to demonstrate the importance of connection, open knowledge and the power of collective intelligence to bridge the gaps in the world's largest encyclopaedia, Wikipedia, focusing on dedicated themes for cultural heritage conservation and climate action.

This past year has been one of the most successful yet for IIC in terms of reach, impact and influence. Fellows and members of IIC have a long history of shaping the organisation. We'll be inviting members to meet with Council and attend an Extraordinary General Meeting (EGM) later in the year and will complete the next membership survey—it's important we hear from you to inform our new strategy to take us into the future.

Sarah Stannage  
*IIC Executive Director*



---

## EDITOR'S SOUNDING BOARD

"The art museum is in a moment of transition." This is a note that Australia-based conservator Asti Sherring rediscovered on her phone—a passing thought that, upon further reflection, became profound in her understanding of our profession in relation to time-based art and the constant evolution of the art world. With several articles in this issue of *News in Conservation* stressing the need for the conservation profession to embrace change, I would like to suggest that this phrase, slightly tweaked, would be an excellent mantra for our community: "the conservation profession is in a moment of transition."

As suggested by Asti Sherring, as well as in articles by Marina Herriges and Julia Betancor, if the conservation community does not embrace needed changes, our practices and philosophies will become outdated, no longer addressing the current needs and issues within the collections, institutions, and public we serve.

If you have engaged with IIC recently, you know that we have delved into many needed changes, including a focus on leading our profession to become environmentally sustainable. As a fun change of pace for *News in Conservation*, our December-January 2022 issue will be dedicated to students and early-career professionals, featuring stories and images about—and by—the rising generation of conservators. We look forward to the energy, innovation, and brilliance that will surely emanate from that issue, benefitting us all.

Sharra Grow  
*IIC Editor in Chief, News in Conservation*



# NEWS IN BRIEF

## CONSERVATION OF THE HARTWELL MEMORIAL WINDOW

Dazzling to behold and impressive in its scale, the *Hartwell Memorial Window* is among the most complex stained glass landscapes produced in America. Soaring 25 feet high, the scene captures Mount Chocorua, one of New England's most beloved peaks, at sunset. More than 100 years ago, Agnes F. Northrop designed the window for Tiffany Studios as a commission from Mary Hartwell in honor of her husband, Frederick Hartwell, for the Central Baptist Church of Providence, Rhode Island (now Community Church of Providence). It remained housed in the sanctuary of the church until 2018, when the congregation decided to relocate the window to the [Art Institute of Chicago](#), where it could be conserved to ensure its long-term stability and remain on public view. Deinstalling, conserving, and reinstalling a stained-glass window of this monumental size and intricacy called for an unprecedented plan—one that maintains the historic integrity of the Tiffany Studios craftsmanship while showcasing the range of the studio's achievements in glass to full effect.

The window's new home in the Henry Crown Gallery at the top of the Woman's Board Grand Staircase is an ideal setting for this majestic work. It is also one that required novel approaches to the window's mounting, framing, and lighting. Every step of the way, Art Institute colleagues worked internally and with external leaders in the fields of conservation, engineering, fabrication, and mount making to establish new best practices for the treatment and installation of stained glass.

Click on the image to watch a lecture about the conservation and installation of the Hartwell Memorial Window and learn more about the project [here](#).

Virtual Lecture: Conservation of the Hartwell Memorial Window

Tiffany Studios Autumn Landscape, 1923-24  
Metropolitan Museum of Art

V&A Whiteley Galleries of Sacred Silver and Stained Glass

Museum of Fine Arts Boston

Arts of the Americas Administrative Coordinator, Esther Espino for scale

7:48 / 41:49

Virtual Lecture: Conservation of the Hartwell Memorial Window. Video courtesy of The Art Institute of Chicago.





Reproduction of the painting after restoration by Dianne Dwyer Modestini, a research professor at New York University. By Leonardo da Vinci - Getty Images. Image Public Domain via [Wikimedia Commons](https://commons.wikimedia.org/wiki/File:Salvator_Mundi.jpg).

## THE LOST LEONARDO NOW PLAYING

A new documentary on the controversy surrounding *Salvator Mundi* was released in September. The film, *The Lost Leonardo* by Andreas Koefoed, comes hot on the heels of another documentary, *The Saviour for Sale*, which premiered on French TV this past spring.

The panel painting has been controversially credited to Leonardo da Vinci by some experts and reputed a fake by others over the last decade. Tensions surrounding the painting reached a new head when it became the most expensive painting ever sold at auction, at \$450m (£326m) by Christie's in 2017, after one of the most hyped pre-auction campaigns in recent history.

However, the drama did not stop there. The painting now belongs to Saudi Prince Mohammed bin Salman, who unsuccessfully campaigned for his new treasure to sit alongside the *Mona Lisa* in the Louvre's 2019 Leonardo da Vinci exhibition. Instead, many speculate that the Prince now holds the painting on his superyacht, away from the public eye. It is apparent that the new documentary is about much more than a painting; the film critiques the use of priceless cultural heritage as pawns by those who hold immense power, whether that power comes in the form of money or professional reputation.

At the heart of the film is renowned conservator Dianne Modestini who has likely gazed at this painting longer than anyone else, having treated the work just before the controversy and auction took the stage not only in the art world but across the entire globe. It seems now that everyone has an opinion on the painting and its story; perhaps all that is left to discover is whether this film will change yours.

## EUROPEAN DAYS OF CONSERVATION-RESTORATION

From Monday 4th, to Sunday 10th October 2021, the European Confederation of Conservator-Restorers Organisations proposed six themes with their respective posters that they posted each day.

The themes are listed on their website (<https://www.ecco-eu.org/european-day-of-conservation-restoration-2020/european-days-cr-2021/>).

As part of European Days of Conservation-Restoration, Conservator-Restorers invited visitors to their working places: in museums ateliers, private studios, university studios and conservation-restoration sites in monuments. Conservator-Restorers explained their actual conservation-restoration projects with case studies to the public.

The European Day of Conservator-Restorer aims:

- to raise awareness of the key role of conservation-restoration in safeguarding cultural heritage with policy makers and civil society (public);



**European Days of Conservation-Restoration**  
European Confederation of Conservator-Restorers' Organisations

**10th October 2021**  
follow and share the activities all around Europe  
4th-10th October 2021

*Join us!*

#ECCOCommunity  
#EuropeanDayConservationRestoration @ecco\_eu

In the legacy of:  
**2018**   
**EUROPEAN YEAR OF CULTURAL HERITAGE**  
#EuropeForCulture

European Days of Conservation-Restoration 2021 poster, courtesy of ECCO.

- to share knowledge of the complex activity of this discrete profession as an applied science which includes humanities, natural science and intervenes with a code of ethics in the many fields of Cultural Heritage;
- to highlight the respect and discovery of the values for society through the interventions beyond artists and crafts for ensuring the integrity of the material witness to guarantee the authenticity of cultural heritage for identification process of the individual;
- to make transparent the international quality standards of the profession on this high level of competences for safeguarding Cultural Heritage through member associations in 22 European states;
- to clarify how this expertise is of value to sustainable tourism and a catalyst for innovation in science for heritage.

The European Week of Conservation-Restoration included a social media campaign held from Monday to Saturday to highlight the European Day of Conservation-Restoration which happened on the following Sunday, 10 October. This European Week of Conservation-Restoration aimed:

- to bring Europe's cultural heritage, history and shared values closer to people;
- to engage the younger generation in the care of cultural heritage;
- to highlight special themes in conservation-restoration which are important in the preservation of Cultural Heritage such as authenticity, awareness, access and sustainability.

Thanks to the splendid #ECCOCommunity for sharing on social media! You can find more information [HERE](#).

#EuropeanDaysConservationRestoration  
#ECCOCommunity





# Willard

CONSERVATION EQUIPMENT ENGINEERS



Quality conservation tools & equipment built to last a lifetime, designed and made in our UK workshops since the 1950's.

Willard hand tools have a proven life expectancy of more than 40 years, making them the sustainable choice for Conservators around the globe.

We offer a bespoke tool and equipment design service, please contact us to discuss your specific requirements, now or in the future, we will always be pleased to assist you.

T: +44(0)1243 776928

E: sales@willard.co.uk

www.willard.co.uk





Plowden Medal Winners Stephen Clare and Professor Jane Henderson with RWAH President Pamela Harper and Plowden Medal Committee Chairman Nick Farrow. Photo credit: Theo Wood Photography

## THE PLOWDEN MEDAL FOR CONSERVATION AWARDED TO PROFESSOR JANE HENDERSON AND STEPHEN CLARE MBE FOR SERVICES TO THE CONSERVATION PROFESSION

The Plowden Medal for Conservation was awarded to Professor Jane Henderson and Stephen Clare MBE at St James's Palace on 29 September 2021 in recognition of their contribution to the field of conservation.

Established in 1999 to commemorate the life and work of the late Hon. Anna Plowden CBE (1938 – 1997), the gold medal was endowed by the Royal Warrant Holders Association, of which she was vice-president.

The Plowden Medal is awarded annually to an individual who has made a significant contribution to the advancement of the conservation profession and whose nomination would be widely welcomed within the conservation community. It covers all aspects of conservation—be they practical, theoretical or managerial—and is open to those working in private practice or institutions. A Selection Board drawn from the conservation community, the Royal Collection and the Royal Warrant Holders Association selects the winner from the nominations. This year the board were so impressed with the entries that they decided to present the medal to two individuals.

Based in Cardiff, Professor Jane Henderson received the award for her outstanding leadership and development of new generations of conservation professionals, her essential role in the development of the profession and her continuing commitment to bringing leading research and innovations into conservation practice in the UK and internationally. She comments, "Conservation is such a wonderful profession. We are a group of people

whose passion is to make things that are special to people stay special. To be recognised along with Stephen Clare for having made an outstanding contribution to an outstanding profession is truly thrilling.”

Stephen Clare MBE, director of Holy Well Glass, is a stained glass conservator based in Somerset who received the award for his outstanding contribution to stained glass conservation and his advocacy for, and support of, student and early career stained glass conservators. Alongside Stephen’s outstanding conservation treatment, his commitment to the dissemination of good practice and the professional training of highly skilled conservators is Stephen’s long-term legacy to stained glass conservation.

He comments, “We are enormously proud of our Royal Warrant as stained glass conservators by Royal Appointment to Her Majesty the Queen. Therefore the presentation of this prestigious award at St. James’s Palace by the Royal Warrant Holders Association particularly resonated with us. I know that Anna Plowden was a great trailblazer for the status of conservators in private practice, so this award gave me particular pleasure as a conservator in private practice. It was most enjoyable, and an honour to share the platform with Professor Jane Henderson, who is a friend, and whose work I greatly admire.”

Nominations for the Plowden Medal 2022 will open in January. For more details visit: <https://www.royalwarrant.org/> and for enquiries contact Claire Anderson: [plowdenmedal@rwha.co.uk](mailto:plowdenmedal@rwha.co.uk)

## Why see half when you can see it all?



From Conservators to Conservators



### LAMPA

3 in 1 Light Source Solution for Art Conservation



### XpeCAM PLATFORM

New Technological Platform for Art Conservation



### XpeCAM X02

Spectral Imaging Hardware Solution

DIC  
DIVE



Ciaran Begley, Bulb #4, 2017, Medium format camera, halogen lamp and screen, image by William Newall, courtesy of the artist.

# DIGITAL DISRUPTION AND EMERGENT CONSERVATION

## OPPORTUNITIES AND CHALLENGES RELATING TO THE DEVELOPMENT OF TIME-BASED ART CONSERVATION IN AUSTRALASIA

By Asti Sherring

*The art museum is in a moment of transition.*

*I found this reflection typed in bold font on 1st December 2019 in my iPhone notes application, months after the idea had first seeded in my mind. I can only assume that this thought came to me in haste (evidenced by the variety of incorrect characters present in the note) while I was going about my daily work. Clearly, I must have felt that this statement was significant at the time, enough so for me to stop what I was doing and type my future self a reminder.*

Reflecting on these words, it seems impossible that I would have forgotten it, as this loaded statement clearly articulates what I had observed in my role as the first time-based art conservator in Australasia. The honour and privilege of being granted this title ensures that I have a front row seat to what artist and philosopher Herve Fischer calls the “crisis in contemporary art”—the digital revolution (Fischer 2000, p.75).

This digital revolution has disrupted the archetype of the 20<sup>th</sup>-century art museum from a place of tradition and contemplation into a space that can be transformed by digital experiences and virtual connectivity.

This transition is driven by cultural changes in the present day which are increasingly mediated by technologies with the ability to engage human senses in different ways, creating new connections. By the end of 2021, it is projected that consumers will own 46 billion connected digital products (Juniper Research 2021) ensuring a continued reliance on external devices as an extension of the human body. Artist practices, artworks and art audiences are also changing—both as a reflection of, and in reaction to, these societal shifts, providing the incentive for art museums to move



beyond traditional media. For the purposes of this article, "time-based art" will be used to refer to digital experiences, heritage objects and artworks that utilise analog or digital technologies, have a duration dimension and which only exist when they are switched on or performed, often requiring activation and active management to maintain functionality. This medium includes video, film, sound and software-based works as well as works that do not have media elements, such as performance works.

Faced with the need to adapt, museum professionals working in cultural institutions are searching for new collection and conservation methodologies which can encompass and care for the complex and variable needs of time-based art collections.

Arguably, the most important role of a cultural steward is "to prolong the existence of cultural material" ([Australian Institute for Conservation of Cultural Materials Code of Ethics, 2002](#)). However, preliminary research I have undertaken in time-based art conservation presents themes and issues that appear to contradict this ethical mandate. First-hand observations indicate that the shock of the new and fear of the now sentiments are very much prevalent within the Australasian sector's current state of awareness and understanding of time-based art. To further investigate, I conducted an online survey which explored many of the themes and issues that have emerged over the course of my research.

My findings, as discussed below, indicate the viewpoints of cultural heritage professionals who advance the discussion of cultural, institutional and structural barriers embedded in working cultures, practices and attitudes. Of the 140 cultural heritage professionals who took part in this study, the majority see the development of time-based art as a distinct specialisation within conservation. However, many feel challenged with the day-to-day management of all aspects of what it means to collect, display and preserve time-based art. As one respondent noted, a "lack of understanding of how to manage all aspects of it [time-based art] means it is time consuming compared to 'traditional' art". The biggest roadblocks affecting the institutional management of time-based art include: the artwork not being identified as an institutional priority; challenges relating to managerial support and institutional advocacy; lack of specialist skills within an organisation and an overall lack of understanding of the key issues relating to the institutional management of time-based art works. As one respondent explained, "currently, museums are not adequately resourced to deal with existing collections of time-based art (to fully document and future proof the works). So as artists explore and push the boundaries of the medium, and technology improves/ expands, museums get further behind".

*"Currently, museums are not adequately resourced to deal with existing collections of time-based art (to fully document and future proof the works). So as artists explore and push the boundaries of the medium, and technology improves/ expands, museums get further behind."*

Survey respondents were hesitant to talk about positive progress in the sector without also acknowledging potential obstacles. Examples include noting a "greater awareness of and future planning to achieve best practice standards, however existing workload volumes, resourcing and infrastructure within institutions could be seen as a limitation", and that the "organisational change required to ensure the needs of these works are met [require] processes and resourcing changes". One respondent noted that time-based art conservation is "still [in the] early days, [but] it seems that institutions are on the edge of solidifying sound processes", while another respondent felt that "we are moving towards better practices as time-based art becomes better understood. I just don't think we are there yet". As one respondent explained, "...this is a very complex, nuanced and multifaceted area of conservation, and one which is only just beginning to really emerge in Australia." In addition to the data presented, respondents also identified several supplementary obstacles such as limited budget and resources; general negative attitudes toward time-based artworks being acquired into cultural institutions; the complex challenge of engaging artists as primary stakeholders in the installation, display and preservation of their work; the knowledge/skill gap between technical skills

and collection management practices and successfully advocating for better time-based art collection management and conservation standards within an institutional environment.

Another reoccurring issue expressed throughout the survey is the lack of specialist skills to support the display and preservation of time-

based art. Over half of respondents identified a lack of specialist skills within their organisation as one of the biggest issues impacting the institutional management of time-based art. One respondent commented that "there are entire collections becoming lost due to the lack of expertise and fear of intervention". The majority of survey respondents agree that there is a need for the establishment of specialist time-based art conservation roles within the cultural heritage sector to ensure the appropriate care and management of this growing category of art. As one respondent observed:

The main issue is the extent of technical knowledge required which I (and perhaps most people in the visual arts) are not (or at least not yet) well versed in. I think quite naturally we lag behind the artists who are embracing new types of media. Traditional registration, cataloguing and preservation practices need adapting to appropriately accommodate time-based art and doing so successfully requires being upskilled and educated in different technologies. Finding the relevant information also involves going outside of the more traditional/conventional sources of information.



Code on Canvas, Untitled (Children's immersive experience with Grayson Perry), 2015, projection mapping installation, National Centre for Creative Learning, Museum of Contemporary Art, Sydney. Image by Jeremy Shaw, courtesy of the artist.



Heath Franco, *ALTERLAND*, 2015, multi-channel audio-visual installation, Australian Experimental Arts Foundation, Adelaide, courtesy of the artist.

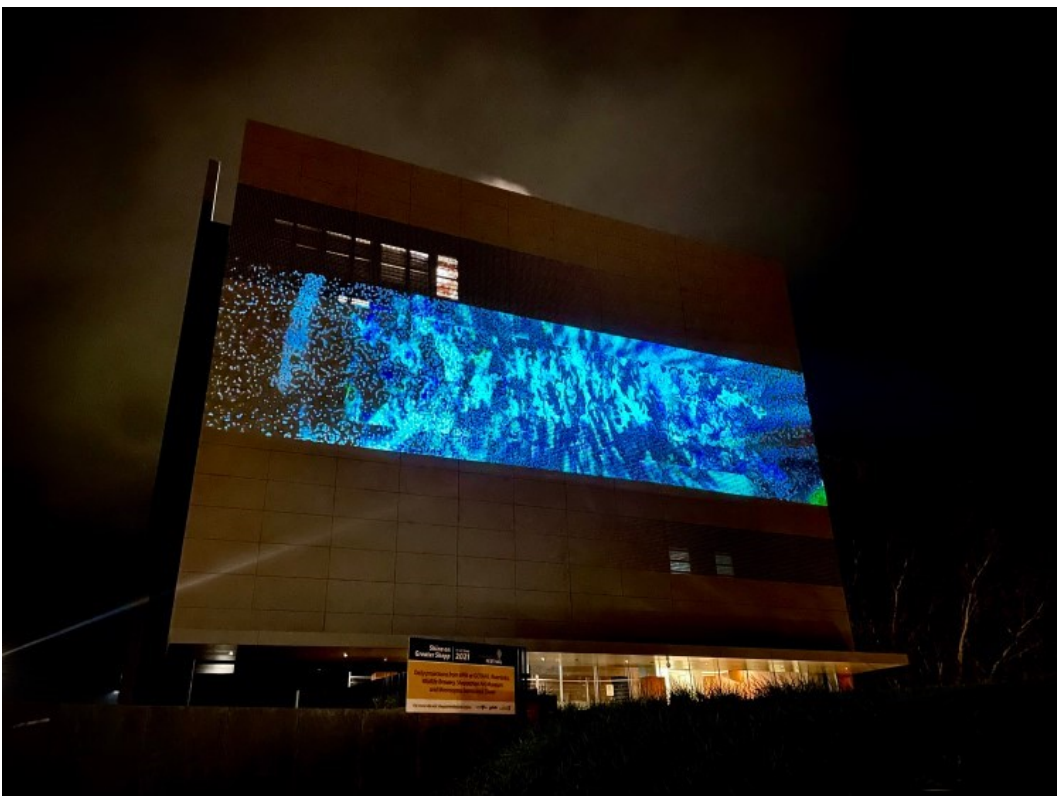

PluginHUMAN (Betty Sargeant and Justin Dwyer), *The Art of Constant Change*, 2021, video artwork commissioned by the Shepparton Festival, courtesy of the artist.

*"In the last century [conservation] has been struggling to define its own identity in response to the rapid changes which have shaped the modern world."*

As it stands, the difficulty is that there are currently very few positions in time-based art conservation in the region and a lack of trained specialists even if positions were to become available. Multiple respondents acknowledged that "the knowledge and skills required to work with time-based art are completely different from those developed and needed for more materials-based conservation like paper, objects etc... And yet there is some expectation that we should be able to just do time-based art conservation". Currently, the development of training in time-based art conservation has seen limited growth both within Australasia and internationally. Without dedicated training programme coursework, conservators working in time-based art generally need to first complete traditional conservation coursework followed by significant independent research, museum fellowships under experienced time-based art conservators, and/or film and sound archival training. It is also possible, as demonstrated at Tate, for professionals with equivalent experience, often in a related audio-visual or information technology field to be employed into the role of time-based art conservator after a period of in-house training (Lawson 2020, pers. comm., 24 June).



"In the last century [conservation] has been struggling to define its own identity in response to the rapid changes which have shaped the modern world" (Pye and Sully 2007, p. 19).

While acknowledging that time-based art conservation is a new field within the still relatively young discipline of conservation, the rapid technological advancements which began to emerge in the late 20th century will continue to push the profession further away from its classical and scientific roots. This sentiment was repeatedly expressed in the survey, where respondents observed that a philosophical, cultural and practical shift from traditional museological practices is required to manage and conserve time-based art. The evolving materiality of the 21st century requires the conservation profession to embrace these rapid technological shifts for the sake of our cultural heritage and our professional reputation. As former General Electric CEO Jake Welch said, "if the rate of change on the outside exceeds the rate of change on the inside, the end is near" (Allison 2014), or as one survey respondent urged;

"... view TBA [time-based art] not as a 'trend' in conservation and object management but as an integral part of how an art museum needs to function in the 21st [century]—that works are no longer restricted to traditional media and an institution needs to keep up with the changes and challenges of artistic expression".

*"... view TBA [time-based art] not as a 'trend' in conservation and object management but as an integral part of how an art museum needs to function in the 21st [century]—that works are no longer restricted to traditional media and an institution needs to keep up with the changes and challenges of artistic expression".*





10-metre-high projection screen being suspended from the roof in Art Gallery of New South Wales 19<sup>th</sup> century “old court” 2020. Image by Asti Sherring.

My research demonstrates that the very nature of time-based art requires a reassessment of traditional institutional roles and workflows, new types of technical knowledge, the development of skills to support the field of time-based art conservation and the creation of lasting supportive networks of practice. As the conservation profession continues to explore the dichotomy between object-hood and virtual spaces, it is imperative that our ability to develop new practices for new materials is not stagnated by the traditional principles of conservation. There will always be new objects which enter into our collective heritage space and “present previously unanticipated conservation challenges” (Pye and Sully 2007, p.29), and so it is essential that conservators acknowledge our subjective role within museological frameworks, including our preconceived notions and personal biases, for the sake of our cultural heritage and for the future of the conservation profession.

This article is a conversational summary of the author’s published research in the AICCM Bulletin. Read Asti Sherring’s full journal paper [HERE](#).

Another link to the full paper:  
<https://doi.org/10.1080/10344233.2020.1809907>

For more information on the artists mentioned in this article, click on the **BONUS CONTENT** button.



**Asti Sherring** is a time-based art conservator. She has completed a bachelor of media arts, Sydney University and a masters of materials conservation, Melbourne University. Asti held the position of senior time-based art conservator at The Art Gallery of New South Wales between 2015-2020. She has also worked at Los Angeles County Museum of Art and Museum of Contemporary Art. Asti is currently undertaking doctorate research at Canberra University.

# OF ENDBANDS AND BE OR OF THE TROUBLES AND LIMITS BOOKBINDING DESCRIPTIONS

By Georgios Boudalis



A selection of nine different endbands, a sample of the variety of techniques used and decorative effects achieved.

# ES

## OF TERMINOLOGY IN



*Since 2010 I have been working on a book about endbands used in codices bound according to various bookbinding traditions of the eastern Mediterranean. As this work now approaches completion, I thought it might be interesting to present the problems I faced and some thoughts on how to overcome the ever present issue of terminology—an issue valid for the myriad natural and human-made things that surround us.*

The term endband is used to designate two bands worked at the head and tail edges of the spine of a book for structural and decorative purposes. The techniques with which they are worked and the ways with which they are connected to a book-block vary greatly in time and space.

Terminology is part of the way we understand and organize the world, and as such it cannot be avoided.

Giving a name to things puts a tag on them, thus dragging them out of anonymity and the chaos which surrounds us, and puts them in a drawer which is then put into a specific place. A name is what identifies things in verbal terms, and if we believe Wittgenstein's saying that "The limits of my language mean the limits of my world"<sup>1</sup>, things can exist only as long as they are named and documented. As the Swedish naturalist and physician Carl Linnaeus (1707-1778) states in his 1751 published *Philosophia Botanica*, "If you do not know the names of things, the knowledge of them is lost too."<sup>2</sup> Names allow us to communicate with other people and describe things in a verbal way, the main—but certainly not the only—way in which humans communicate.

<sup>1</sup> *Tractatus Logic-philosophicus* 5.6.

<sup>2</sup> Carl Linnaeus, *Philosophia Botanica*, 1751, Aphorism 210.

## HOW ARE NAMES GIVEN?

Names are often descriptive, based on or describing one or more features of the thing that they refer to. These can be technical features (for example twined endbands, from the twining technique used to make them); structural features (for example primary and secondary endbands, from the sequence of their making and the structural importance of these two basic components of compound endbands); visual features (for example chevron endbands, named after the chevron pattern that is formed through their working); ethnic, cultural, chronological or geographic attributes (for example, Coptic, Armenian, Byzantine endbands); or a combination of any of the above. Such names can be borrowed from other contexts, or they can be newly invented for the specific needs of each occasion.

Although technical terms can be used colloquially for years, they need to be published in order to become part of our official technical vocabulary. Nowadays there is an intense effort to compile glossaries or thesauri of technical and art historical terms<sup>3</sup>. Among those specifically focused on bookbinding, we should mention the *Language of Bindings* thesaurus (LoB), a cross-institutional project hosted by Ligatus at the University of the Arts London. LoB is an online illustrated thesaurus which aims to elaborate on terminology and classification of bookbinding<sup>4</sup>.

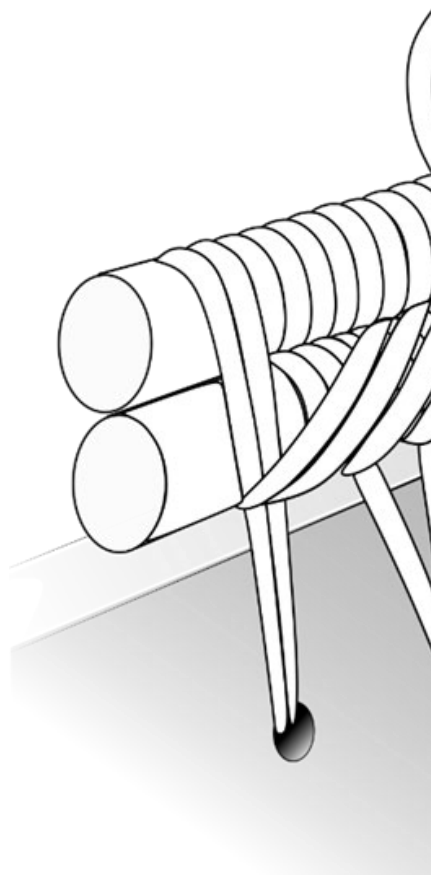

## ONE NAME OR MULTIPLE NAMES?

In my research I have tried to use technical terms rather than terms referring to the tradition of origin although in the end I have realized one can live with both as long as one defines and describes them properly. An example is the Armenian endband; the technique used to make these elaborate and very decorative and distinct endbands is not specifically Armenian but is also commonly found and used in Syriac, Georgian and Byzantine bindings. In some of these traditions they were used before the earliest examples that we have from Armenian bindings. Therefore it is only logical and scientifically accurate to try and describe these endbands primarily in a more neutral way, for example in purely technical terms. They are all twined endbands and more specifically full-wrapped-on-multiple-additional-cores-rounded-twined-endbands. Nevertheless there are still features which can be used to distinguish between such a twined endband as used in an Armenian, a Syriac or a Byzantine binding. For example there are features such as the staggered endband tie-down holes on the boards or the size and distribution of the cores used which can make a full-wrapped-on-multiple-additional-cores-rounded-twined-endband an Armenian endband. As long as we are aware of these special features which can turn a full-wrapped-on-multiple-additional-cores-rounded-twined-endband specifically into an Armenian endband we could use both or either term without risk of confusion or inaccuracy.

Should this be considered a problem? Should we be worried about these different ways of naming bookbinding features: empirical on one hand and more elaborate and scrutinized on the other? I don't think so. As long as we have a clear definition of what the features of such an endband are, in theory any name could work. Besides written definitions, visual definitions are extremely helpful as they directly illustrate the visual and structural qualities which distinguish these endbands and their varieties.

To take an example from the natural world, the commonly known bird, great tit or titmouse, has only one scientific name, *Parus major*, but as many as sixty common names in English alone<sup>5</sup>. Despite the huge number of common names, there is no confusion as

.....  
<sup>3</sup> See for example the Getty vocabularies <https://www.getty.edu/research/tools/vocabularies/>

<sup>4</sup> <https://www.ligatus.org.uk/lob/>

<sup>5</sup> Michael Ohl, *The Art of Naming*. The MIT Press, 2019, pp. 32-33.

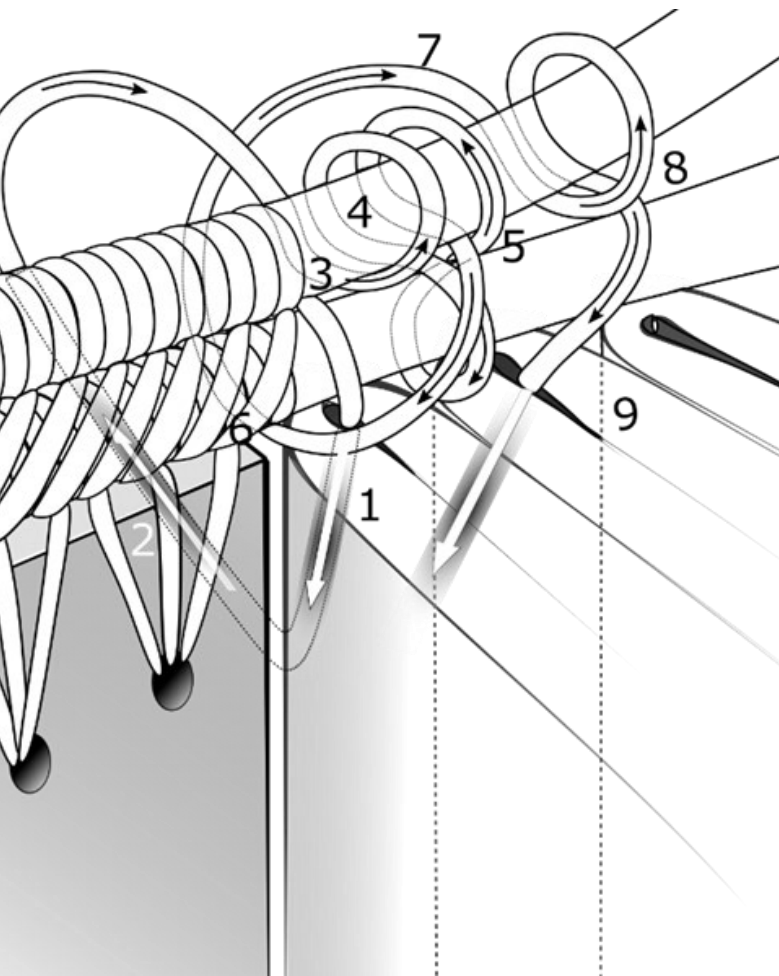

Top: A technical drawing describing one of the ways the *Slanted-stitches-on-two-cores* endband, (also known as *Greek on two cores* endband). The drawing is accompanied by a verbal description following the numbers shown. Drawing by G. Boudalis.

Right: A drawing showing the anatomy of an Armenian endband. Drawing by G. Boudalis

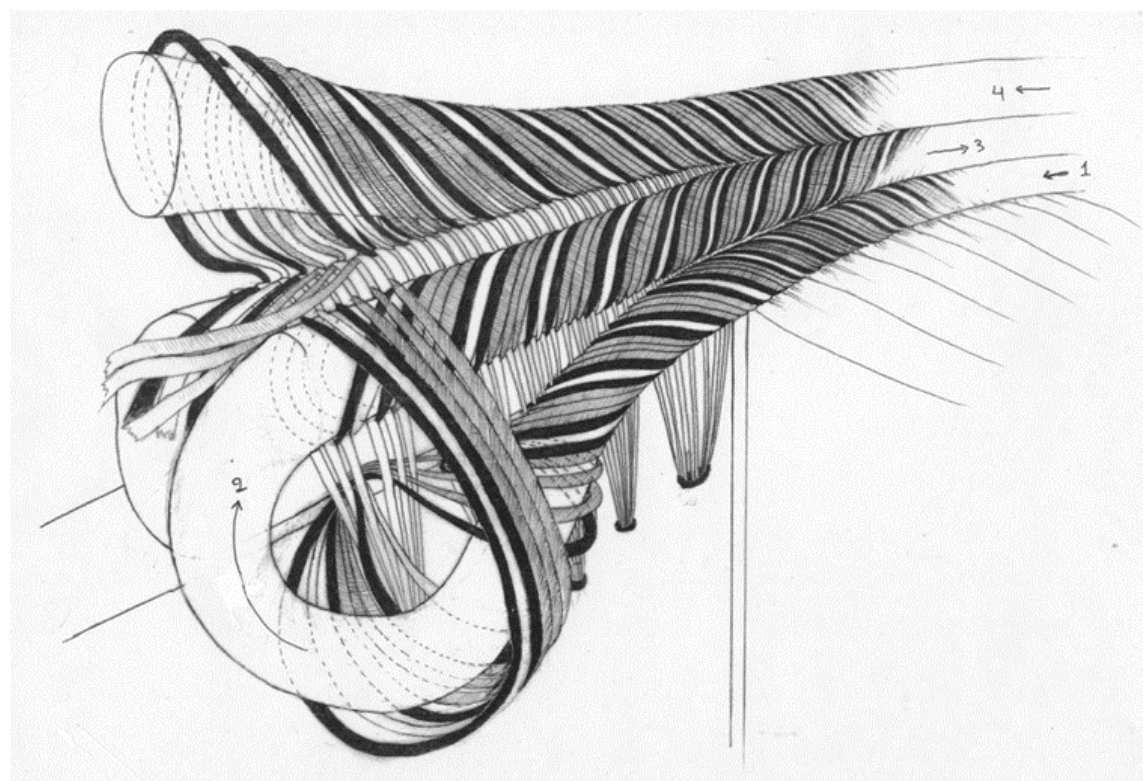

there is only one official name and an official description of the species behind the name. This description specifies its anatomy, physiology, behavior and all the other particularities which make this a distinct species.

### NAMING AND UNDERSTANDING

The name we give to things is the result of our understanding and our perception of them. The better we understand something the more likely it is that the name we give to it will be accurate and hopefully lasting. It certainly helps to consider things in a wider context—technological as well as cultural—as the same techniques are often used in different contexts, and therefore in some cases we don't really need to invent new terms but need only adopt or adapt those already used.

Since terminology reflects our understanding of things, we should accept that the process of naming is fluid and ongoing. This takes time, and it is a long process. In my struggle to name different endbands and different components or processes, I have been comforted by the fact that taxonomy of living creatures has been an ongoing process since antiquity. New species are named almost every day while others are renamed and/or reclassified. As taxonomic and evolutionary knowledge advances, this inevitably affects the way organisms are arranged in the taxonomic system. DNA analysis now seems to be the ultimate solution to the unequivocal classification of living organisms. Is there anything that could be used in a similar way in our field? Should we think of the artifacts we call books, in a way, as living things and therefore deal with them as evolutionary taxonomists deal with living creatures on earth?

## THE SIGNIFIER AND THE SIGNIFIED OR THE NAME AND ITS MEANING

Names or terms are conventional designations which work as long as members of a community agree on their meaning. In other words no matter what something is called, the important aspect is agreement on the term's meaning. This is an important distinction to make and to understand because we seem to be focusing more on the terms we use rather than understanding and defining exactly what they mean. The latter is often a problem because we often don't really know much about the things we try to describe and designate. Understanding as deeply as we can the thing we want to name is of special importance for technical descriptions, and in that sense the definitions are more important than the names themselves. These definitions can and should be written but it is of huge help to have illustrated examples too, especially when describing processes. To continue with the analogy of classification from biology, the formal description of every species (of animal, plant etc.) includes detailed drawings which aim to define—as clearly and precisely as possible—the organism classified. Therefore by describing the process of production of an endband, we can provide a definition of the thing. As I have explained elsewhere, visual definitions have the huge advantage of being direct and can overcome language barriers.<sup>6</sup>

My definitions of the endbands I have identified, named and classified are based on a combination of visual and written descriptions of their production aiming to provide as much clarity as possible.

## THE BOOK AS A LIVING ORGANISM, OR WHAT CAN TAXONOMY TEACH BOOKBINDING HISTORIANS

Until the 17<sup>th</sup> century, some authors called the honeybee “*Apis pubescens*, thorace subgriseo, abdomine fusco, pedibus posticis glabris utrinque margine cillatis”, which translates as “furry bee, grayish thorax, brownish abdomen, back legs smooth with hair on both sides”. It was only through Carl Linnaeus’ binomial system of classification that this became simply and elegantly *Apis mellifera*, meaning honey-bearing bee.<sup>7</sup> These two words are now capable of identifying one single species of bee no matter how many common names this might have within different languages.<sup>8</sup> The long descriptive name of the honey bee above reminded me of some of my endband names such as the full-wrapped-on-multiple-additional-cores-flat-and-vertical-twined-endband, the longest name of the over sixty endbands which I have catalogued and described.

In my quest for identifying, classifying and naming endbands, I have somehow ended up following the opposite process to that of the taxonomy of living organisms; my own scientific process of describing and naming has ended up with often long and composite names unlike the bipartite names of plants, insects and animals. What they do have in common is the awkwardness of some of these names and the difficulty in memorizing them.



Above: A drawing showing the anatomy of an *Apis mellifera* worker bee. From *The ABC and XYZ of Bee Culture*, by A.I. Root and E.R. Root. The A.I. Root Company: Medina, Ohio (1910) p. 54. (Image in public domain. Source: [Wikimedia Commons](https://commons.wikimedia.org/wiki/File:Apis_mellifera_worker_bee.jpg))

.....  
<sup>6</sup> See Georgios Boudalis, ‘One Drawing is worth a thousand words’, *Icon News* July 2015 (11). 11-13.

<sup>7</sup> There are five species of the genus *Apis*. *Apis mellifera*, our honey bee has 30 subspecies. See <http://www.atlashymenoptera.net/page.aspx?id=238>

<sup>8</sup> On the binomial nomenclature—that is, the denomination of each kind of plant by two words, the genus name and the species name (thus ‘*Apis*’ is the name of the Genus and ‘*mellifera*’ is the name of the species) see <https://www.huntbotanical.org/OrderFromChaos/OFC-Pages/intro.shtml>. See also <https://biologydictionary.net/taxonomy/> and [https://en.wikipedia.org/wiki/Taxonomy\\_\(biology\)](https://en.wikipedia.org/wiki/Taxonomy_(biology))



There is no reason why these long names should not or will not be left aside in favor of common names which will be coined by the people making, studying, repairing and speaking about them. However, since they have been identified, classified, described, named and published, that long name will remain the official name to which other names will refer in order to avoid confusion and misunderstandings.

## CONCLUSIONS

Struggling with terminology myself for years, I've realized that we have to accept that it is a rather fluid, and to an extent, subjective thing.

We need to focus equally, or maybe mostly, on the definitions rather than the terms themselves. Inevitably definitions require research, study and close inspection of the things we name and define, and we must accept that the terms we propose are not carved in stone. More research will inevitably require adjustments and corrections to the terms we use, terms to which we have become accustomed—or even attached to—and therefore often resist changing them, even when we understand the reasons why such changes should be made. After all, old words—like old habits—die hard.

## ACKNOWLEDGMENTS

I am grateful to Athanasios Velios and Andrew Honey for reading this short article and making valuable comments and suggestions.

Interested in Georgios Boudalis' research on ancient codices and his exquisite accompanying illustrations? Read Jane Eagan's review of Georgios Boudalis' book *The Codex and Crafts in Late Antiquity* found in the [April-May 2021 "News in Conservation" Issue 71, p. 33-35.](#)



**Georgios Boudalis** is the head of the book and paper conservation laboratory at the Museum of Byzantine Culture in Thessaloniki, Greece. His research interests focus on the techniques and evolution of bookbinding structures in the Eastern Mediterranean. He is the author of the book *The Codex and Crafts in Late Antiquity* published in 2018.





# ROBIN HODGSON: LOOKING UP IN LOCKDOWN

By Christopher Lawrence

*She calls it her 'rural bit of Paradise', but with a rolling series of Covid lockdowns in the Australian state of Victoria, conservation engineer Robin Hodgson has turned isolation into an opportunity. With self-sufficiency, the legacy of a childhood on the land and the great distance from her principal markets in the US & Europe already conquered by technology, Hodgson's life is almost business as usual.*

The roadside sign among the grapevine-shrouded hills of the Mornington Peninsula points to Meakin's Rise, on which nestles a discreet cottage and an expansive workshop – opposite poles of the owner's current existence. Midway through the state's sixth lockdown, one of the tightest in the world, Hodgson is largely confined to the perimeters of her paddock fences. That still leaves plenty of space for tending to a huge vegetable garden, keeping mind and body together.

Counter clockwise from top left:

Robin Hodgson posing with her motorcycle.

View from Robin's home, overlooking a local vineyard.

In one corner of Robin's workshop: a CNC 5.5Kw Router with 3 x 1.5 m bed.

Robin's bovine neighbours, viewed from her home at Meakin's Rise in Victoria, Australia. All images courtesy of Robin Hodgson.

"As a single person living on my own, it's been challenging", she says. "But I look at the bigger picture and imagine how it was for others in inner city apartments. I have six acres on which to take exercise 24/7."

Dubbed by Williamstown Arts Conservation Center's associate paintings conservator, Maggie Barkovic, as "a famous saviour in the world of art conservation" for her world-renowned skills as a designer and fabricator, Hodgson's country resilience comes from her childhood on a dairy farm, not so far from Meakin's Rise, where she was one of seven children.



“Artistic we were not”, she says with a smile. “Practical, yes. Farming is essentially not terribly profitable on a family scale. We had to learn to make do a lot of the time, fixing our own equipment and maintaining things. If you didn't have a bit of machinery, it was unlikely you'd be able to afford to buy it, so you'd go out to the scrap pile to try and cobble something together. To this day, I still have neatly racked scraps of steel and little interesting components that I may have found in something – bits of equipment that could be repurposed into jigs, machine dies or specialist pieces of machinery for my manufacturing.”

This early passion for making things, combined with a diagnosis of dyslexia, took the teenager out of the Australian secondary school system early and into an apprenticeship as a cabinet maker. Hodgson set up her own workshop at home and worked informally with a local craftsman whose techniques harked back to a former age, fostering her profound appreciation for hand skills and problem solving in a fine-skilled trade.

“We can plane a board flat, make a square cut with a hand-saw, carve dovetail joints by hand, hand-fit drawers—cabinetry skills that weren't in general use by then. Wood turning, too. In a trade sense, I don't know anyone who can do it to the level that I can, and as quickly.” This mastery of traditional methods and fascination for the bespoke marries well with the function and aesthetic of Hodgson's current output. “I turn out the handles on my heated spatulas because no one else could do it at the same price.” Not just home crafted, but home-grown: the wood they are turned from is harvested from the wood lot on Robin's property.

After four years making reproductions of eighteenth-century furniture, Hodgson moved to London in 1980 to study the real thing. “I had good hand skills by that time, and very quickly I realized that a lot of the furniture I wanted to research had been, let's say, poorly restored, and therefore much of the actual information I wanted to find was no longer there. I *could* have undertaken a course in furniture restoration, but most places had in sight the training of restorers for the antique trade. That was never my interest. I knew what conservation was. I knew it was a term beginning to be applied to paintings, but in furniture forty years ago it was unheard of. My area at the time just happened to be furniture, but that soon broadened to include other wooden objects.”

Robin spent years in the V&A Museum library and then in France, researching original source material and forming a philosophy of conservation that would inform her subsequent work in other media. “I feel it's very important that conservators *do* what conservators are meant to *be*, and that is impartially preserve the history that we have,” she says. “If we *restore* it, we are rewriting history.”

Back in Australia from the late '80s, she became involved with the Australian Institute of Conservation and soon gained a reputation as a problem-solver, starting with a



Robin, striking a pose at the 2018 IIC Congress dinner in Turin, Italy. Image courtesy of [unintelligible]



Photo by Robin Hodgson.

wall mural in a building marked for demolition. “It was the headquarters of the Waterside Workers Federation in Sydney, and it was making way for a parking lot. The wharfies (as we call them down here) wanted to take the mural away with them—but it was twelve meters long and two meters high, so I was asked by my colleague Andrew Thorn to make a saw that could cut the plaster off the brick wall and piers while keeping everything intact. It took me ten minutes to think something up that I then went away and made. The whole experience was so satisfying. I realized I wanted to pursue this line of work further.”

Word spread about Hodgson’s unique combination of expertise in furniture making, structural engineering, metals fabrication, electronics and bespoke design. A request from paper conservator Trish Stokes in Victoria resulted in the creation of a cold suction table, while the Queensland Art Gallery’s then conservation head John Hook inspired the hot suction table for structural treatments of paintings on canvas. The practitioner’s tool kit was enhanced by what has become Robin’s current signature product: the non-contact infrared heat tool, capable of locally heating a surface of 25mm diameter to a predetermined temperature to consolidate a fractured or flaking surface, enabling the sensitive non-contact treatment of artworks. In a recent (June 2021) edition of *Artnet News*, Brian Boucher describes the device as one of “...the snazziest tools and technologies conservators are exploiting.”

Interest from the US in Hodgson’s work necessitated frequent trips across the Pacific to demonstrate her creations at conferences and lecture on their application at universities such as Yale. Those who have encountered Robin in these forums won’t have forgotten her; she is always the most striking physical presence in the room. Equally beyond dispute is the quality of finish. Every product is personally and painstakingly manufactured by the designer herself in her country workshop—right down to those turned wood handles.

The pandemic has put a stop to Hodgson’s always enthusiastic trans-Pacific travels for the time being. “I was overseas on trips for around 3-4 months a year”, she admits, “supporting my clients, fostering new ones, backing up my products and, importantly, being seen. When I started to promote my products in the US people would say ‘oh, but you’re in Australia!’, the inference being that I wasn’t going to be around in case after-sales service was needed. I believe I’ve overcome this now by offering after-sales service second to none in this field, in person and via the RH Conservation Engineering website ([www.rhconservationeng.com](http://www.rhconservationeng.com)).”

For Robin, more time at home has meant more time for the business with the chance to consolidate operations, replenish stock levels and commission new pieces of CNC (computerized numerical control) equipment together with learning CAD (computer-aided design) to start to drive them. The former dairy farm kid with the scrap pile has been able to rebuild older machines from scratch, finding

**Top:** Robin demonstrating RH Conservation Engineering equipment for participants at the Yale "Conserving Canvas Symposium" in October 2019.

**Bottom:** RH Conservation Engineering Infrared Heat Tool. Images courtesy of Robin Hodgson.



that the repetition improves both productivity and quality. Above all, lockdown has bought time to think. "I'm seeing that so many conservation treatments have been on hold through lockdowns", she says. "I know there's so much catching up to be done. I've always strived to enable my profession to be more productive through the equipment I've developed and see this time as opportune to move forward with greater efficiency and with the appropriate technology.

"I love challenges. I love solving problems simply. It's a sense of service. In life, there's always a better way of doing something."

*Special thanks to the FAIC Oral History File housed at the Winterthur Museum, Library, and Archives (USA) in the preparation of this article.*



**Christopher Lawrence** is a writer, broadcaster and arts administrator based in Tasmania, Australia. He works extensively with symphony orchestras, music education and festival presenters, and his books about classical music are available in Australia, the UK, US, Hungary and China.



# NIC CALL FOR NEWS

INTERNATIONAL INSTITUTE FOR CONSERVATION OF HISTORIC AND ARTISTIC WORKS

*Some of the youngest newsies hanging around the paper office after school. Location: Buffalo, New York (State). Photographer: Lewis Hines. 1910. Library of Congress, Prints & Photographs Division, National Child Labor Committee Collection, [reproduction number, e.g., LC-USZ62-108765]. Original location <https://www.loc.gov/pictures/item/2018674175/>*

## SHARING IS CARING

*News in Conservation* is dedicated to publishing the latest in conservation news from around the world, but we can't do it without you!

Do you have something to share? Chances are, you do! So don't keep it to yourself; send your news and article proposals to *News in Conservation*. Your contribution will benefit the global IIC professional community.

## WE LOVE ARTICLES ABOUT:

- New studies, research, and projects
- Event and publication reviews
- Opinion pieces
- Calls for participation or collaboration
- Global conservation news (both uplifting and catastrophic)
- Highlighting cultural heritage initiatives, programs, and funds
- The latest from conservation students and training programs
- Images, videos, and links
- And so much more!

If you have news, *NiC* wants to share it! Submissions and enquiries can be sent to:

Sharra Grow  
IIC Editor, *News in Conservation*

[news@iiconservation.org](mailto:news@iiconservation.org)

Kate Smith  
IIC Communications Consultant

[communications@iiconservation.org](mailto:communications@iiconservation.org)

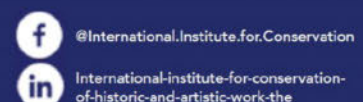

IIC, 3 Birdcage Walk, Westminster, London SW1H 9JJ. Email: [iic@iiconservation.org](mailto:iic@iiconservation.org) [www.iiconservation.org](http://www.iiconservation.org)

The International Institute for Conservation of Historic and Artistic Works (IIC) is a learned society, a registered charity and a company limited by guarantee with no share capital. Charity No. 209677. Company No. 481522.

**INTERNATIONAL COMMUNITY CHALLENGE: A TIME FOR CLIMATE ACTION IN CULTURAL HERITAGE CONSERVATION**

We are delighted to announce that the IIC has been chosen to attend and represent our field on the world stage at COP26 UN Climate Change Conference in Glasgow, 30 October to 11 November 2021. We will be one of the few exhibitors in the Green Zone as part of the two-week conference.

This is our opportunity as an international body for conservators and cultural heritage professionals to contribute to the global agenda on climate change. We know it is incumbent on all of us to adapt, innovate and pioneer change, and at IIC we intend to lead by example.

We are seeking support from IIC members, universities and institutions, whether through direct participation in the Edit-a-Thon or technical and subject specialist contributions to the project, to help us deliver our programme for COP26 – live in Glasgow.

**EXHIBITION AND 24-HOUR GLOBAL EDIT-A-THON - LIVE IN GLASGOW AND ONLINE 10-11 NOVEMBER 2021**

As part of COP26 we are organising a 24-hour global Edit-a-Thon online to demonstrate the importance of open knowledge and the power of collective intelligence to bridge the gaps in the world’s largest encyclopaedia, Wikipedia. We will be focusing on dedicated themes for cultural heritage conservation and climate action.

We are reaching out to our members, universities and partners around the planet, and our ambition is to bring together over 250 students, researchers and affiliated scholars from conservation courses, with each group taking up the baton, and by working in preferred languages, to edit Wikipedia in two-hour-long sprints.

The **24-hour IIC COP26 Edit-a-Thon #IICEditsForClimate** will take place between **10-11 November 2021**.

The Edit-a-Thon will be launched live during the COP26 UN Climate Conference with coordination and promotion through the main COP26 exhibition programme in the Green Zone.

We’ll be tracking progress online and promoting throughout via social media. We will also be organising an “open door” networking session open to all our members and participants in the Edit-a-Thon, from Fellows to students, to join us online at the COP26 UN Climate Conference.

**IIC** PARTICIPATE W

**IIC Edit-a-Thon**  
online and live at C

**10 - 11 November 2021**  
[www.iiconservation.org](http://www.iiconservation.org)

**PROJECT KEY DATES**

- 11 October:** Draft schema circulated to partners
- 20 October:** Student and University registration deadline for training
- 25 October week:** Editing training sessions (2 x 1-hour options) + 30 minute drop-in session (datesTBC)
- 5 November:** Participants Sign-up deadline to Wiki dashboard for editing
- 10-11 November:** Edit-a-thon, live from COP26
- 12 November:** Open Door Networking Event for participants (TBC)
- End of November:** Post-event survey + impact report

# WITH IIC AT COP26



# COP26

**TOGETHER  
FOR OUR  
PLANET**

#TogetherForOurPlanet  
#COP26  
#IICEditsForClimate

*"The IIC COP26 Edit-a-Thon is a great chance to be a part of a unique event aiming to increase valuable knowledge for the conservation field and encourage other professionals to engage in the climate change agenda. It is an opportunity for students to collaborate with colleagues and at the same time improve editing, peer reviewing and online publication skills. I am looking forward to working with you all in this fantastic event. Get involved!"*

—Marina Herriges, IIC Edit-a-Thon Coordinator

## KEY ENGAGEMENT PARTNERS: UNIVERSITIES

We are inviting universities to support the initiative as engagement partners with the opportunity for student cohorts to take part in two-hour long sprints within the 24-hour period. We are currently working out sprint slots across the various time zones to suit partner universities. A final list of universities will be confirmed in early October. If universities have certain education assignments or special areas of interest for students, we are keen to hear your ideas to feed into the programme!

## EDITING TRAINING, PROJECT DASHBOARD + IMPACT

Online editing training sessions for students will be programmed to suit various time zones for October 2021 (dates to be confirmed shortly). Recorded training materials will also be accessible on the IIC Community platform for participants to view in their own time. We'll also be creating an online **Wiki Dashboard**, where editors will be able to login and join the Edit-a-Thon session remotely. This will help us track the knowledge uploaded to assess impact; as data is aggregated we are able to share results with universities.

Information about the project and updates on signing up for editing training, dates and times will be circulated to IIC members, participants and will be published to the IIC Website: <https://www.iiconservation.org/COP26Edit-A-Thon>

## SCHEMA AND SUBJECT SPECIALIST SUPPORT

Key senior individuals from IIC, AICCM and ICOM-CC, along with universities, will be invited to feed into a **schema** for the Edit-a-Thon, to guide students and participants taking part. We'll be circulating a draft schema on 11 October.

## KEY PROJECT CONTACTS

IIC Edit-a-Thon Coordinator and Associate Editor for Environmental Sustainability: **Marina Herriges:** [marina.herriges@gmail.com](mailto:marina.herriges@gmail.com)

IIC Executive Director: **Sarah Stannage:** [ExecDir@iiconservation.org](mailto:ExecDir@iiconservation.org)

We're also hosting Wikimedian(s) via **UK Wikimedia**, who are an important technical partner to provide support, mentoring and editing training. The programme lead for Wikimedia and Connected Heritage is Dr. **Richard Neville**



# PHD

# PROJECT

# PROPOSAL



## EMERGING CONSERVATOR ZOOM TALK: PHD PROJECT PROPOSAL

INTERNATIONAL INSTITUTE FOR CONSERVATION OF HISTORIC AND ARTISTIC WORKS

*After the successful Emerging Conservator Zoom Talks earlier this year, IIC is organising a follow-up series of Zoom Talks focused on PhDs in conservation.*

*The series will aim at informing potential candidates of the steps required before, during and after the PhD process, as well as practical tips. This series will include sessions on:*

1. Writing a project proposal (8th of December 2021)
2. Finding the right supervisor (date TBD)
3. Funding your research project (date TBD)
4. Life after the PhD (date TBD)

**In the first session, the focus will be on the relevant characteristics of successful project proposals: What does a successful project proposal comply with? How do I make my proposal stand out? How can we apply project proposals from other professions to ours? Why are some project proposals rejected?**

This series of Zoom Talks will be accessed through the **IIC Community Platform**, so if you are interested in participating in the LIVE talk with Q&A, as well as having access to the resulting resources, recordings and later discussions, make sure to register for a member account on the IIC Community Platform now! Registration for this series of Zoom Talks is free of charge for IIC members. **Registration will be made available soon.**

For more information about IIC's Community Platform follow this link: <https://www.iiconservation.org/participate/our-new-iic-community-platform>





## FEATURED JOB LISTINGS

### [2022-2023 Fellowships at the Metropolitan Museum of Art](#)

Employer: The Metropolitan Museum of Art

Location: New York City

Salary: 42,000 (USD)

Contract: Full-time

Application deadline: 3 December 2021

*Each year, The Met creates a closely knit community of scholars whose individual interests collectively illuminate the Museum's collection of artworks spanning 5,000 years of human creativity... (click job title for more information)*

### [Assistant Conservator, Textiles](#)

Employer: Art Institute of Chicago

Location: Chicago

Salary: 45,500 (USD)

Contract: Full-time

Application deadline: 20 November 2021

*With varying degrees of supervision, the Assistant Conservator carries out examination, research and treatment of objects in the permanent collection, providing ongoing care to textiles of all provenance and times... (click job title for more information)*

### [Junior Restaurator & Medewerker Papier](#)

Employer: Rijksmuseum

Location: Amsterdam

Salary: 2,634-4,053 (Euro)

Contract: Part-time

Application deadline: 10 October 2021

*Het Rijksmuseum is het museum van Nederland voor kunst en geschiedenis met een collectie van ruim 1 miljoen objecten van en over Nederland vanaf de Middeleeuwen tot en met de 20ste eeuw... (click job title for more information)*

### [Junior Restaurator Fotografische Materialen](#)

Employer: Rijksmuseum

Location: Amsterdam

Salary: 3,099-4,053 (Euro)

Contract: Full-time

Application deadline: 10 October 2021

*Het Rijksmuseum is het museum van Nederland voor kunst en geschiedenis met een collectie van ruim 1 miljoen objecten van en over Nederland vanaf de Middeleeuwen tot en met de 20ste eeuw... (click job title for more information)*

### POST A JOB THROUGH IIC

*It is free for everyone to post a job at our standard tier and get noticed by thousands of conservators and heritage scientists who visit the [IIC site](#).*

*Featured listings are £100 or FREE to IIC Institutional Members. These will appear at the top of our job listings, will also be promoted on social media, and will now be featured in News in Conservation. If you would like a featured listing, simply tick the appropriate box on our [job listing form](#) and we will be in touch to arrange payment. If you have any queries, do contact us at: [office@iiconservation.org](mailto:office@iiconservation.org)*

## FELLOWSHIP CORNER

**Rosanna Kuon Arce** is an architect, master in museum and cultural management, and conservator of easel paintings in private practice. She is a founder of the Centro de Investigación y Conservación de Patrimonio at the Universidad de Ingeniería y Tecnología –UTECH, in Lima, Peru and a researcher of interdisciplinary projects at this institution. She launched the Conservation and Restoration Department at Museo de Arte de Lima (MALI), is a former consultant in conservation to UNESCO on various heritage projects, and is coordinator of several seminars with local and international conservators.



Rosanna launched the Conservation and Restoration Department at MALI. Image courtesy of Rosanna Kuon Arce.

**Foekje Boersma** has been the head of collection care at the KB National Library of the Netherlands since 2018. Her work passion lies in implementing more sustainable climate control strategies, and she is currently working on plans for a new remote storage facility using passive climate control. Prior to joining the library, she worked as the program manager establishing the Managing Collection Environment initiative at the Getty Conservation Institute. She was originally trained as a textile conservator, but her career led to preventive conservation and collection management, and she has been fortunate to have worked in different institutions on several large-scale preventive conservation projects. She has always enjoyed being involved with training and dissemination, collaborating with professional colleagues and institutions such as ICCROM. She has been very fortunate to have met so many wonderful colleagues from around the world through her work and is honoured to have been elected FIIC.



Foekje is head of collection care at the KB National Library of the Netherlands. Photo credit Jos Uljee, KB National Library.

## MEET OUR TRUSTEES

**Joyce Townsend** was an editor of the IIC London 2008 Congress preprints as well as a member of the local organising committee for that congress, representing Tate on a committee formed of staff from the major London museums, and monitored the congress budget. She has been IIC's director of publications since 2009. She has since acted as lead and production editor for all IIC congresses from IIC Vienna 2012 onward. Though not a regular editor for *Studies in Conservation*, Joyce is production editor of all special issues and supplements for the journal including the Forbes Prize Lecture and other unique publications. Currently, she is acting as guest editor and production editor for the special issue of *Studies in Conservation* that will form the proceedings of the *Conservation and Philosophy: Intersections and Interactions* two-day virtual event organised in November 2020 by the IIC Special Interest Group on Authentication.

Joyce has also been a trustee of IIC since 2009 and hence a member and officer of the IIC Council. As director of publications, she owns the relationship between IIC and its successive publishing partners and also ensures that IIC is compliant with copyright law. For a number of years, this partner has been Taylor & Francis Routledge. She keeps up to date with changes in the field of journal publishing—in particular the move from print to online access, open access initiatives and the increased use of alternative metrics for the impact of published papers—and conveys these to the IIC Council. *Studies* has evolved over her tenure from a print-only journal distributed to IIC members to an online journal containing at least double the number of papers with an increasing readership and impact factor. It's likely that the journal will completely transition to digital publication online by IIC's 75<sup>th</sup> birthday, and in 2022 the congress preprints will only be available online.

Joyce's first degree, from the University of Glasgow, UK, is in physics which was then known as natural philosophy. She was a conservation scientist at Glasgow Museums for eight years, examining and analysing a variety of materials as well as carrying out environmental monitoring and materials testing, before moving to Tate in London to take up a funded doctoral project on *The Materials and Techniques of J. M. W. Turner R.A. 1775-1851*, in which she concentrated on deterioration and changes in appearance of both his paintings and his watercolours. This, and the interpretation of artists' techniques, has been a recurring theme in her subsequent research and numerous publications. She obtained the doctorate in 1991 from the University of London, Courtauld Institute of Arts, and has been senior conservation scientist at Tate since then. Initially she worked on the analysis of modern painting materials and plastics as well as the materials of traditional British art: the first full-time conservation scientist in an institution has to cover many aspects of the collection! Today she covers all periods of British art, with most expertise on the 19<sup>th</sup> and early 20<sup>th</sup> centuries as well as early 20<sup>th</sup>-century international art. The techniques of optical and electron microscopy, microfading and colour measurement—those she uses most regularly—reflect her physics background. She has supervised many Tate projects and many doctoral students. She is author and editor of several Tate books on British artists and has written for many different audiences. Joyce has also edited numerous conference proceedings, many produced by Archetype Publications, London, and she gives lectures and webinars.

Joyce transitioned to part-time work at Tate three years ago in order to spend even more time on writing and editing. Her book *How Turner Painted: Materials and Techniques* was published in 2019. She has plans for others, and she is now series editor for the Routledge *Science for Conservators* series in addition to being honorary professor in the School of Culture and Creative Arts at the University of Glasgow, which hosts a master's level programme in technical art history.



IIC Director of Publications Joyce Townsend. Image taken by Tony Smibert.

# 2021 IIC-SECC SESSION SPEAKERS 14-16 OCTOBER 2021

The 2021 IIC-Student & Emerging Conservator Conference is 14-16 October, and the final programme for the conference is out!

You can download the programme on the conference website along with further information on each session, speakers, and virtual tours.

Check out the session moderators and speakers. More information and conference website links [HERE](#).

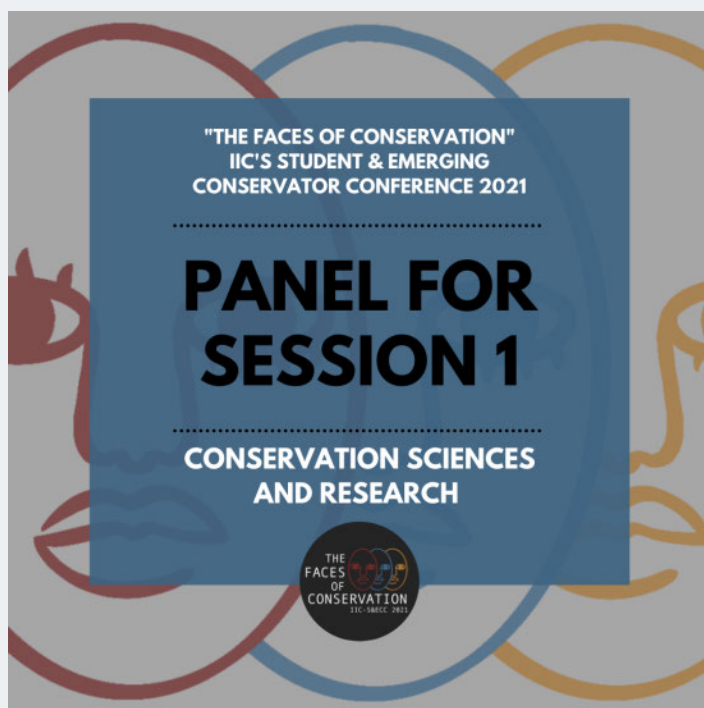

"THE FACES OF CONSERVATION"  
IIC'S STUDENT & EMERGING  
CONSERVATOR CONFERENCE 2021

**PANEL FOR  
SESSION 2**

**CONSERVATION AND  
RESTORATION**



"THE FACES OF CONSERVATION"  
IIC'S STUDENT & EMERGING  
CONSERVATOR CONFERENCE 2021

**PANEL FOR  
SESSION 3**

**PREVENTIVE CONSERVATION  
AND MANAGEMENT**



THE FACES OF CONSERVATION IIC-IBICC 2021

SESSION 2  
15TH OCT.

MODERATOR  
**ÉLIS MARÇAL**  
ARTERESTAURO - CONSERVAÇÃO DE BENS CULTURAIS LDA; ECCO



THE FACES OF CONSERVATION IIC-IBICC 2021

SESSION 2  
15TH OCT.

SPEAKER  
**CARMEN ROYO FRAGUAS**  
CENTRO NACIONAL DE CONSERVACIÓN Y RESTAURACIÓN, CHILE



THE FACES OF CONSERVATION IIC-IBICC 2021

SESSION 3  
16TH OCT.

MODERATOR  
**HÉLIA MARÇAL**  
DEPARTMENT OF HISTORY OF ART, UCL  
FACULTY OF SOCIAL & HISTORICAL SCIENCES



THE FACES OF CONSERVATION IIC-IBICC 2021

SESSION 3  
16TH OCT.

SPEAKER  
**NATASHA HERMAN**  
REDBONE BINDERY BOOK CONSERVATION;  
STILT BOOK CRADLES



THE FACES OF CONSERVATION IIC-IBICC 2021

SESSION 2  
15TH OCT.

SPEAKER  
**SANDRA ŠUSTIĆ CVETKOVIĆ**  
ŠIBENIK DEPARTMENT FOR CONSERVATION  
OF THE CROATIAN CONSERVATION INSTITUTE



THE FACES OF CONSERVATION IIC-IBICC 2021

SESSION 2  
15TH OCT.

SPEAKER  
**MAMTA MISHRA**  
INDIAN NATIONAL TRUST FOR ART AND CULTURAL  
HERITAGE - INTACH CONSERVATION INSTITUTE



THE FACES OF CONSERVATION IIC-IBICC 2021

SESSION 3  
16TH OCT.

SPEAKER  
**MOHAMED WAHEED ALI**  
NATIONAL MUSEUM OF EGYPTIAN CIVILISATION



THE FACES OF CONSERVATION IIC-IBICC 2021

SESSION 3  
16TH OCT.

SPEAKER  
**SARA ABRAM**  
FONDAZIONE CENTRO CONSERVAZIONE E  
RESTAURO "LA VENARIA REALE" - CCR



THE FACES OF CONSERVATION IIC-IBICC 2021

SESSION 2  
15TH OCT.

SPEAKER  
**MÓNICA SÁNCHEZ**  
UNIVERSITY OF ALICANTE

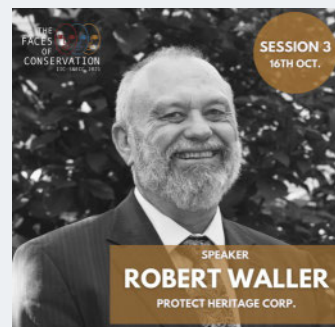

THE FACES OF CONSERVATION IIC-IBICC 2021

SESSION 3  
16TH OCT.

SPEAKER  
**ROBERT WALLER**  
PROTECT HERITAGE CORP.



THE FACES OF CONSERVATION IIC-IBICC 2021

SESSION 3  
16TH OCT.

SPEAKER  
**JENNY WILLIAMSON**  
NATIONAL LIBRARY OF WALES; GLYNN  
VIVIAN ART GALLERY



# SUSTAINABILITY: WHAT WE CAN LEARN FROM A HOLISTIC APPROACH

By Marina Herriges

*Climate change widespread, rapid and intensifying – This is the title of the disturbing report by the Intergovernmental Panel on Climate Change (IPCC) released in August 2021. The current situation is alarming. IPCC scientists have been studying changes in the planet’s climate and presented some of the changes already being considered irreversible, like the continued sea-level rise. The global temperature is predicted to rise by at least 1.5°C in the next 20 years. According to the IPCC, “the role of human influence on the climate system is undisputed”, and carbon dioxide is “the major driver of climate change”.*

Despite how sad and worrying this report is, the good news is there is still time to adjust, focus on acting promptly and see climate change as an opportunity for our profession to change (as scary as this word may sound to us conservators) and keep ourselves relevant.

In this issue I would like to discuss sustainability, but not from my perspective or that of researchers; I believe that it is essential to hear from our colleagues who can share their experiences and diverse points of view. I interviewed four professionals from different parts of the world who have experience integrating environmental sustainability in their conservation practice. Şolá Akíntúndé is an architecture conservator and founding trustee at the West Africa Shared Cultural Heritage Trust in Lagos, Nigeria. Saiful Bakhri is a conservator at Bali Cultural Heritage Preservation Office in Bali, Indonesia. Foekje Boersma is head of collections care at KB National Library of the Netherlands in The Hague, Netherlands. Ellen Ferrando is collections care supervisor at the Instituto Moreira Sales in Rio de Janeiro, Brazil.

Through the below subheadings, I present our main points of discussion as well as related concerns. Of course, this is just a brief compilation of thoughts, and I am aware that we have much more to cover, but this discussion is a good start to engagement and reflection with some ideas for how you can join the conversation.

## INTERDEPENDENCY BETWEEN ENVIRONMENT, COMMUNITY AND ECONOMY

In its early existence, the concept of sustainability was initially tied solely to the environment. Throughout the years, the term has evolved, and social and economic dimensions have been integrated resulting in an interdependency between the three concepts. In Saiful Bakhri’s opinion, these three factors must be considered alongside each other in developing sustainable conservation practices. Saiful used a recent technological invention as an example: “Electric cars might be great in terms of environmental sustainability. Yet, it is not economically sustainable if only a few people can access them due to their price.”

Ellen Ferrando reinforced this idea saying that “it is our accountability to conserve natural resources and protect the global ecosystem, to support the health and wellbeing of all species, right now and in the future.” This idea brings the environment and the community into the discussion, which are crucial in taking steps to address climate change issues.

Sarah Sutton and Elizabeth Wylie define environmental sustainable practices in their book *The Green Museum* as approaches which “rely on renewable materials and processes that enable continued use and practice into the future.” The use of renewable resources was also referred to in the interviews. Şolá Akíntúndé recognized the importance of “ensuring that locally abundant and renewable materials are given priority in the material palette of conservation sites.” Renewable is a term commonly used in sustainability, but we cannot rely on this concept without changing our behavior. In Foekje Boersma’s opinion, environmental sustainability means “caring for cultural heritage in a way that makes responsible use of the world’s resources. We should avoid depleting natural resources and not only pass our heritage on to future generations but also the resources to continue to care for it.” She understands that making choices is key for this to happen: “we

can no longer think of conservation as a means to keep everything forever or for damage not to occur." This is a thought-provoking view, as by considering the environment, we may change the way we understand and even practice conservation.

#### CONSERVATION AND ENVIRONMENTAL RESPONSIBILITY

"I cannot understand our profession being disconnected from a sense of responsibility towards people, the environment and nature." This is the idea Ellen presented to me. In a profession where most of us focus on the object as the driver of our conservation practice, considering people and the environment might seem wild. However, we preserve objects that are representative of human beings and the ecosystem which should have the same importance—or even priority—in our decision making which can have real consequences for the planet we live on. Foekje understands that environmental sustainability is "crucial for conservation" and says that "it actually gives us opportunities to do things better, with improvements not only for collections but also for organisations, communities and the world." She sees the benefit of, for example, using passive climate control measures to counter the effects of climate change as well as making institutions more economically sustainable. Ellen states that it is a matter of having to make choices, in which "being more aware of sustainable choices [regarding] materials, approaches, and their ecological, social, and economic impact should play a relevant role in conservation".

#### INCLUDING ENVIRONMENTAL SUSTAINABILITY IN OUR DAILY CONSERVATION PRACTICES

Locally sourced materials, as well as traditional techniques, are important when looking into environmentally sustainable practices. Şolá identifies the manufacture of heritage items as a "potential area to learn as well as to identify materials that harm the environment and should never be repeated or the ones that should be emulated." Traditional techniques are also the main content of a book published by the Southeast Asian Regional Centre for Archaeology and Fine Arts and the Queen Sirikit Museum of Textiles called *Our Ancestors Knew Best: Traditional Southeast Asian Textile Treatments and their Place in Modern Conservation*. The publication features the importance of a person-environment-centred approach in conservation, optimising the use of locally and regionally available natural resources rather than importing materials with conservation purposes. They investigated methods used in traditional textile treatments that can potentially be applied within the wider conservation profession. In this case, we are talking about textile conservation, but I am sure there are other conservation disciplines joining in the effort.

Taking a deeper dive in relating conservation to community and traditional practices, Saiful mentioned the Balinese philosophy, Tri Hita Karan, as a way to live in harmony with nature, implementing the philosophy's learnings in his work. As a result, his research looks at potential environmentally derived alternatives to synthetic or toxic treatments. Saiful explained how he developed a technique which uses citronella essential oil as an environmentally friendly material to remove mosses and lichens from stone (recently featured in the [August-September 2021 "NiC" issue 85, p.12-15](#)).

Greenhouse gas emission  
from **human activity:**

**>80%**  
since 1970.

Source: IPCC

If we reach  
**2°C** of warming:

**>3 billion+** facing severe heat waves

**>410 million+** facing water scarcity

**>up to 10%** global livestock lost

Source: IPCC



Page 38 images, clockwise from top left: Ellen Ferrando (Image courtesy of Ellen Ferrando) / Solá Akíntúndé (Image courtesy of Solá Akíntúndé) / Foekje Boersma; KB Image Studio (Jos Uljee) / Saiful Bakhri (image courtesy of Saiful Bakhri)

Opposite page: Both images created by Marina Herriges using data from the recent IPCC report.

Ellen once again stressed the importance of changing in our behaviour; Ellen has transitioned her conservation practice to using less toxic solvents and reusing materials like paper, boards and foams as well as nitrile gloves when they have not previously been in contact with harmful substances. Using the stairs instead of the lift can also be a good idea, said Ellen. She also spoke about a very important way to address sustainability: “every time I have the chance, I try to expand the scope and make others around me understand the impact of their actions from a broader point of view, trying to raise environmental awareness throughout the organization.” This is a great way to engage colleagues, in a casual non-intimidating way, in the bigger conversation.

Reducing our carbon footprint was likewise an important goal brought up during my interviews. Foekje, for example, is looking toward creating a passive building with an automated storage and retrieval system, built with the circular economy in mind, for the national library collection; this will allow her institution to decrease its carbon footprint. Ellen also said that environmental management is a priority for the institution she works for. She and her colleagues established a team to research environmentally sustainable improvements within the organization. Involving other professionals in the debate is always good, allowing us to hear different perspectives as well as helping us to change as a community and not just individually.

I found it inspiring to speak with professionals from different areas of the world who have been contributing to the climate agenda. Although this column is called “Environmental Sustainability”, it will be impossible not to touch on subjects like community and the economic side of sustainability. By bringing these three concepts into the discussion, we will better understand the need for collective action and a cohesive professional voice in addressing climate change in conservation.

I see the current climate crisis as an opportunity for us to change our behaviour as we re-evaluate attitudes and practices that perhaps will not suit conservation going forward. In an informal conversation with IIC President Emeritus Jerry Podany, he presented me with an interesting thought: “It will require not only a change in our daily practices but [also] in our expectations and a re-evaluation of the status quo that we have become both comfortable in and dependent upon.” Expectations are something that we deal with on an everyday basis in conservation, and we like to stay in our comfort zone; these might take hard work to overcome, but by addressing these issues, we will make our profession relevant for the future as well as engage in subjects that the whole planet should be fighting for. Following Ellen’s thought, “transformation happens when mentality changes.”



**Marina Herriges** works as a textile conservator at Textile Conservation Limited in Bristol, UK. She holds an MPhil in textile conservation from the University of Glasgow. She currently researches embedding environmental sustainability in conservation education at the Kelvin Centre for Conservation and Cultural Heritage Research at the University of Glasgow. Marina has worked in a range of different heritage and conservation organizations in Brazil, Portugal, Spain and the United Kingdom.

# OUR COLLECTIONS MATTER: ENABLING SUSTAINABILITY THROUGH COLLECTIONS AND CONSERVATION

By Henry McGhie and José Luiz Pedersoli, Jr.

*What do heritage collections have to offer in today's fast-paced world and in the face of tremendous social, environmental and economic challenges? How can heritage professionals contribute to meeting these challenges, and how should they do so? These questions relate both to the relevance of collections and to the practices of those who are entrusted with their care. To contribute effectively to sustainable development, heritage professionals need to understand their responsibilities and the potential of collections, be committed to supporting the effective use of collections and have the practical skills and opportunities to put collections to work to make a difference.*

In 2015 the world's governments agreed upon a new programme for sustainable development called Agenda 2030, which was presented in the document "Transforming Our World". This aims to address the world's problems and put the world on a path to a sustainable future. We are a long way from that world, with a variety of social, environmental and economic challenges. Agenda 2030 has five overarching aims, which can be summarised as the 5 Ps:

**People:** To end poverty and hunger, in all their forms and dimensions, and to ensure that all human beings can fulfil their potential in dignity and equality and in a healthy environment.

**Planet:** To protect the planet from degradation, including through sustainable consumption and production, sustainably managing its natural resources and taking urgent action on climate change so that it can support the needs of the present and future generations.

**Prosperity:** To ensure that all human beings can enjoy prosperous and fulfilling lives and that economic, social and technological progress occur in harmony with nature.

**Peace:** To foster peaceful, just and inclusive societies which are free from fear and violence. There can be no sustainable development without peace and no peace without sustainable development.

**Partnership:** To mobilize the means required to implement this Agenda through a revitalised Global Partnership for Sustainable Development, based on a spirit of strengthened global solidarity, focussed in particular on the needs of the poorest and most vulnerable and with the participation of all countries, all stakeholders and all people.

Agenda 2030 will run until 2030, and it already has a lot of support across all sectors, including the heritage sector. A key part of the Agenda is the set of 17 Sustainable Development Goals, which are the results framework for the Agenda. The goals were

Top Left: Our Collections Matter – a new initiative from ICCROM. Logo © ICCROM

Bottom Right: The 17 Sustainable Development Goals, part of Agenda 2030. Image made available for information purposes by the UN. Original image located here: <https://www.un.org/sustainabledevelopment/news/communications-material/>



developed through an extensive consultation and are made up of 169 targets, or sub-goals, which are much easier to work with in practical terms. A set of official indicators was also developed, but these are primarily aimed at governments which must report on their countries' progress at the United Nations.

Where does this leave the heritage sector? Agenda 2030 is based on active, free and meaningful participation (a principle of human rights), and it is set out as an invitation for all sectors to collaborate in addressing the world's challenges. The Agenda is, in fact, an excellent opportunity for the heritage sector—and all other sectors—to work together and demonstrate the difference it can make in the world. Not only will this benefit the goals and Agenda 2030, it will also benefit the heritage sector itself, helping heritage practitioners and organisations to foster effective partnerships and a resilient and robust collections infrastructure.

ICCROM recognises that collections can contribute to all 5 Ps of sustainability and all 17 Sustainable Development Goals by contributing to cultural participation, education, research, responsible tourism, adopting renewable energy and reducing consumption and waste production. Conservation has a key part to play, ensuring that collections are well maintained, in good condition and ready to be used to support sustainable development. Building on this recognition, the project Our Collections Matter was launched in early 2020 to encourage those working with collections to direct their work towards supporting Agenda 2030 and achieving the Sustainable Development Goals.

Our Collections Matter has been established to support the heritage sector using a strategy with three main strands which we call the 3 Ts or Triple T approach:

**Tools:** we help you find useful tools, reviewing them and highlighting how they contribute to the Sustainable Development Goals and targets. We have developed a specific set of indicators that you can use to further help you plan your activity. The online Our Collections Matter Toolkit (<http://ocm.iccrom.org>) is a carefully curated set of over 160 quality tools (some informational, some frameworks including reports, videos, other toolkits and more) that originate both from inside and outside the heritage sector. We provide you with a summary of the tools' contents and explain how they

## SUSTAINABLE DEVELOPMENT GOALS



link to the Sustainable Development Goals and targets to help you plan, deliver, monitor, evaluate and communicate your activity in sustainable development terms. You can access the tools in four different ways: through the 5 Ps, by collections activity, by Sustainable Development Goals or by Sustainable Development Goals target.

**Training:** we have taken part in events to help partners understand Our Collections Matter and make use of the toolkit and tools. We will be developing further training and development opportunities.

**Transformation:** having the tools and understanding how to use them empowers those working with collections and those impacted by related public engagement, research and partnership activities to take part in the transformation that we need, in terms of our priorities, practices, approaches, activities and the difference that we make as a result.

Our Collections Matter is supported by a strong international partnership including many of the major heritage organisations and covering different collection types. We believe collections, conservation and conservators have a part to play in “Transforming Our World” and invite you to join us in this endeavour. If you have any questions, please contact us via the following email address: [collectionsmatter@iccrom.org](mailto:collectionsmatter@iccrom.org)

*Transforming Our World, the 2030 Agenda for Sustainable Development, <https://sdgs.un.org/2030agenda>*



Our Collections Matter – a new initiative from ICCROM. Video © ICCROM. Watch the video above or click the link [HERE](#).



**Henry McGhie** has a background as an ecologist, museum curator and senior manager. He set up Curating Tomorrow in 2019 to help museums and similar institutions to enhance their contributions to sustainable development agendas, including the SDGs, climate action and biodiversity conservation. He has been working on the Our Collections Matter initiative since early 2020.



**José Luiz Pedersoli Jr.** has a background in polymer chemistry and paper-based heritage. He was a conservation scientist at the Netherlands Institute for Cultural Heritage (1997-2003) and ICCROM (2005-2008). He has done international work on risk management for cultural heritage since 2005 and has been back at ICCROM since 2018, managing the Strategic Planning Unit and a portfolio of projects on collections, risk management, and sustainability.

# IT IS EASY BEING GREEN... FOR IIC MEMBERS

There is a growing list of resources online for conservators, whether you want to begin by looking at supplies and meaningful recycling, or are part of ambitious plans to start transforming whole businesses or institutions. Here are a few useful resources we've gathered for you in a fun and interactive layout. IIC Members can login to the IIC Community Platform and download the "Starter for Ten" PDF or access it on ISSUU. Links and files available [HERE](#) on the IIC Community Platform. Or click the BONUS CONTENT button.







**"STARTER FOR TEN"**  
ENVIRONMENTAL SUSTAINABILITY RESOURCES

INTERNATIONAL INSTITUTE FOR CONSERVATION OF HISTORIC AND ARTISTIC WORKS

There is a growing list of resources online for conservators, whether you want to begin by looking at supplies and meaningful recycling, or are part of ambitious plans to start transforming whole businesses or institutions. Here are a few places to look:



**It IS easy being GREEN**

*"Whoever said 'it's not easy being green' (and I think it was Kermit the Frog) was not entirely right. Being green is not that difficult in itself. Actually, it can be surprisingly easy to make a difference (and surprisingly cheap), but sometimes we just need a helping hand to work out where to begin, or where to go next."* ([Green Museums](#), a step-by-step guide)

**Podcast: Conservators Combating Climate Change**

If you're a bit daunted by the idea of complicated toolkits, the 'Conservators Combating Climate Change' podcast, from the Emerging Conservation Professionals Network, is a good place to start. Over two seasons, it mixes the big picture with small practical actions, looking at how sustainability is interwoven with wider issues of representation and social justice. If you want to understand COP26, who is leading work among conservators and the wider museum sector and what networks are out there, Caitlin Southwick on [How to get involved](#) is a good start on this front.



**Choosing Materials: resources on the footprint of individual products**

*"At what cost to our health and to the environment do we protect, preserve, and exhibit cultural heritage? How can we tell, reliably?"* ([Planning a Life Cycle Analysis](#)). What swaps can you make in your conservation lab for more sustainable options? AIC's [Sustainability and Chemicals](#) wiki offers substitutions and alternatives. Cradle to Cradle is a database evaluating materials used in conservation, in a project led by Sarah Nunberg, Sarah Sutton and Mathew Coughlin. [This article](#) lays out what the project hopes to achieve.

Image: Hand holding globe, by Jemel Furman 2020. CC BY 2.0 / Flickr. Kermit the Frog, by Kevin Colvers 2009. CC BY SA 2.0 / Flickr. Conservators Combating Climate Change, courtesy of Natalya Sazonova and Emma Hartman. Plant and chemicals, by Mariana E. Martins

**Environmental Guidelines**

In 2014, IIC and ICOM-CC finalised [Environmental Guidelines](#) advocating for collection care that do not assume air conditioning, but use passive methods alongside simple technology that is easy to maintain. The Australian Institute for the Conservation of Cultural Material has since developed [their own plan](#), which describes how they will survey the current picture of practice in Australia, then develop guidelines for a country with many different climate zones.



**Creating a whole business or institution action plan**



Making a whole business or institution environmentally sustainable is often a major piece of work, especially if it involves building renovations. But that shouldn't frighten you off from looking at your whole organisation. Julie's Bicycle has produced this [seven page guide](#) to setting up an achievable plan for action without needing major technical knowledge. The Australian Museum is one of the institutions that has progressed the furthest towards achieving net zero: despite operating out of a historic building. [Listen to Dr. Jenny Newell speak](#) about how they've done it.

**Eco-Friendly Art Packing and Transport: are we stuck in bad habits?**



Did you know Dutch museums and galleries have been using a 'turtle' – a reusable crate based on surfboard technology – to transport major artworks around the world for the past 25 years? Learn more in the recent [News in Conservation article, p.16-20](#). This begs the question: Why hasn't this approach become more widespread? And why does our sector continue to fall back on single-use packaging? IIC Fellow Peter Cannon-Brookes has been thinking about this since the '60s, even before the widespread use of plastics. Read his [NiC essay here](#) (p. 61-63).

**Measuring your starting point**



*"Targets make things happen"* (Sarah Staniforth, IIC President Emeritus)

Megan de Silva and IIC's Secretary-General Jane Henderson have produced ["Sustainability in Conservation Practice"](#), a free-access article from the *Journal of the Institute of Conservation*, which is a benchmarking guide specifically for conservators. [Julie's Bicycle recently reported](#) that only a minority of visual arts businesses currently measure their carbon footprints, but doing so is the first step to making progress in your own business. Find additional [carbon calculators here](#), reviewed by green museums leader Sarah Sutton.

**More comprehensive searchable directories**



ICCROM has recently launched its Our Collections Matter toolkit in beta, a directory bringing together many projects. It is currently in beta, with 162 resources, and IIC is among the partners. Watch the [one-minute introduction here](#), and consider completing this survey to improve the resource.

Sustainability in Conservation is gathering a larger directory including a bibliography, websites, conferences and multi-media, well worth exploring for a particular topic or depth of knowledge. [Explore the new resource centre here](#).

Images: Carbon footprint, Fixed Design/Shutterstock.com. Solar panels on the roof of the Australian Museum, Abran Powell/Australian Museum. Packing crate arrow, by Shona Grew. Target, Things/Shutterstock.com. Our Collections Matter © ICCROM

# THE RENAISSANCE RESTORED

## PAINTINGS CONSERVATION AND THE BIRTH OF MODERN ART HISTORY IN NINETEENTH-CENTURY EUROPE

Reviewed by Kimberly Frost

*The Renaissance Restored: Paintings Conservation and the Birth of Modern Art History in Nineteenth-Century Europe*

By Matthew Hayes

Getty Publications, Imprint: Getty Conservation Institute, Los Angeles

208 pages / 56 color and 50 b/w illustrations

ISBN 978-1-60606-696-6

How many times have modern conservators removed a pigmented varnish or a generously overpainted repair while saying ... “what were they thinking?” Hold that thought—it turns out those past restorers might have been considering a great deal of information. Indeed, this book argues that conservators of the present could greatly benefit from studying what motivated these “bad” restorations of the past.

*The Renaissance Restored* charts the parallel growth of paintings conservation and art history through their formative years in nineteenth-century Europe. By assessing individual artists and local actors, the author, Matthew Hayes, presents this past with insightful details gathered from archival documents and historical texts. The result is a reflection on the dialogue and the disconnect between these two disciplines and their modes of coexistence that continue to the present day.

The book is divided into four chapters; the first two chronicle early scholarship on Giotto and Titian. The third and fourth chapters present the role of conservation in forming the interpretations of the Renaissance presented in the national museums founded in London and Berlin. The names of Eastlake, Bode, Hauser, Molenti, Marini, Pettenkofer, and others may be familiar to conservators of old master works. But beyond our broad judgments, what do modern conservators know about their influence on the appearance and historical understanding of paintings in the past and present? This book attempts to bridge that gap, bringing forward the knowledge, philosophies, and relationships that guided these early restorations.

Despite historic esteem from Vasari and others, appreciation of Giotto and other early Italian Renaissance painters decreased, leading to the painting-over of many works. This was the situation in both the Peruzzi and Bardi family chapels at Santa Croce, and likewise in the Magdalene Chapel of the Bargello, when it was converted into a prison. Gathering personal correspondence, historic photographs, and archival documents, Hayes lays out the re-discovery, conservation, and restorations of these monuments. Just like today, conflicting opinions arose.

The artist-restorers faced demands from the church and their clients to prioritize legibility and completion. They turned to surviving fragments and historic manuals to interpret and complete the paintings. However, the results were often decried by contemporary art historians who were no longer able to see the hand of the painter. Artist and sponsor of the Bargello recovery, Seymour Kirkup, was so unhappy with its treatment that he published his own archaeological sketch said to document the fresco before its “harmful” restoration. Hayes suggests that these differences in the desired functions of Giotto’s murals was due to conflict in scale. Art history was an international movement motivated by new

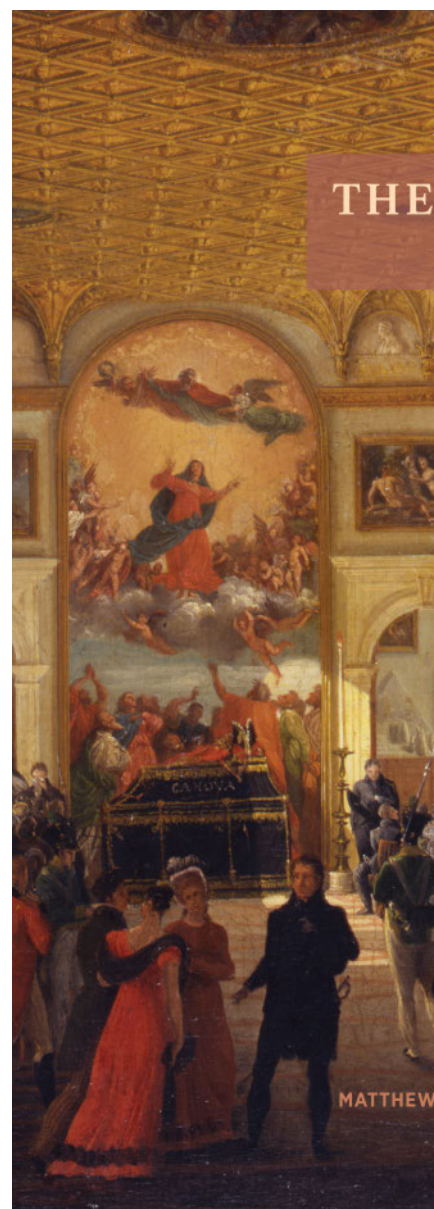

Book cover for *The Renaissance Restored*, co

practices in connoisseurship, but restoration decisions depended on local agency of the church custodians, chapel patrons, and the conservator.

No discussion of Renaissance painters would be complete without Titian, and this volume does not disappoint. The author examines six case studies across Titian's career. The questioning of attributions is presented along with the conservation history of each work. In a modern twist, Hayes points out that conservators and historians had entered a feedback loop; views on Titian's techniques and his place as a painter of color and nature endorsed decisions that reinforced these visual qualities in his paintings. For example, the *Venus of Urbino* was treated using Pettenkofer's method of varnish regeneration specifically because its glazed surface was thought to be sensitive to direct solvent use. The application of selective toning layers was seen as necessary to correct damaged or missing glazes. This echo chamber encouraged maintenance of stasis during restorations and generated an air of uncertainty concerning attribution and assessment of Titian's oeuvre.

The topics above display what Hayes terms an "independent relationship" between paintings conservation and art history. On the face it might seem that this separation resulted in negative outcomes, but the results were clearly positive when considered from the viewpoint of the clients or the conservators. Separation between the two fields allowed conservators and art historians to make autonomous decisions that were informed by their own research and knowledge.

In the next two sections, Hayes explores the opposite scenario: What happens when conservation decisions are not made freely and instead are subsumed and controlled by larger agendas imposed by the museum, the historian, or the public? The chosen examples of Charles Eastlake at the National Gallery London and Wilhelm von Bode at the founding of Berlin's Bode Museum illustrate the complexities that arise from these relationships.

Bode aimed to collapse the distance between past and present. His museum would enhance the aesthetic effects of the artworks by surrounding them in a historically appropriate atmosphere. As a result, conservation was seen as a tool to mask earlier damages to paintings and bring them into a state that reflected the ideals of beauty, monumentality, harmony, and perfection. On the other hand, Eastlake reached a similar conclusion from a slightly different motivation. From previous public hearings, he believed that once a painting entered public view it could no longer be altered. He maintained strict oversight, judiciously seeing to the restoration of all newly acquired paintings before their display. Despite his professed minimalism, Eastlake asked restorers to make changes to elements that he deemed poor in taste or unsatisfactory in design. This was done with the goal of educating students, improving public taste, and avoiding critiques. Eastlake's concern over public knowledge continues to reverberate, especially in modern debates surrounding public sharing of conservation processes and artwork conditions.

The documentation presented here shows that Bode and Eastlake both took a very active role in conservation

*"The factual re-examination of these past figures reveals how they shaped many of the philosophies conservators use today. Instead of dismissing them this book asks: 'Would we have ever come to this point without the early experimentation and scholarship of these restorers?'"*



Courtesy of The Getty Conservation Institute

decision-making. This dynamic relationship between conservation and art history can encourage sharing of data and knowledge among experts. However, it is important to consider what may be lost when conservators or historians are swayed; a painting's appearance may be significantly changed to fit a chosen viewpoint. It can therefore be dangerous if this relationship is not also accountable to outside forces like public opinion.

*The Renaissance Restored* is rooted in the close research and examination of these case studies. This book is for anyone with an interest in Renaissance artworks and the history of their collection and conservation. The interdisciplinary nature of the subject will appeal to art historians, curators, art scientists, and conservators, especially those focused on paintings.

Compared to other books on the history of conservation, this text presents a deeply detailed view focused on a specific location, art movement, and era. The accuracy of the information and images are superb. The author has united previously unpublished material from many disparate archives in a coherent narrative. However, this strength in details may be a shortcoming for some readers. The litany of names may feel taxing or confusing, but a helpful aid was the inclusion of short biographies that profile the most important figures who appear in the text. The factual re-examination of these past figures reveals how they shaped many of the philosophies conservators use today.

Instead of dismissing them this book asks: "Would we have ever come to this point without the early experimentation and scholarship of these restorers?" It was their rigorous study of art history and science that molded art conservation into the distinct discipline it is today.

This publication articulates a great starting point for further discussion and exploration of the links between art history and conservation

across other times and spaces. It touches upon concerns that are still relevant today and highlights the conflict between viewing paintings as archival documents, where damage must be accepted, or as aesthetic objects that require a repaired and coherent image. A similar corollary is the debate over who should have access to the information contained in these different states of an object. Is it ethical for conservators to publicly share their treatments? How much information is too much?

Despite increasing transparency in the art world, conservation and condition facts are almost never made public on museum websites. Perhaps one reason modern conservators avoid this topic is the tendency to align ourselves more with scientists or doctors. Have we come to terms with the fact that our profession still requires subjective interpretation? Openly acknowledging the role that opinions play in our treatments could help modern conservators stay conscious of the impacts they may have on the current and future history of artworks.

*"Have we come to terms with the fact that our profession still requires subjective interpretation?"*

This is an abbreviated version of Kimberly's review. Read the FULL VERSION on the IIC Community platform. Click the BONUS CONTENT button.



**Kimberly Frost**, after a degree in technical art history at the University of Glasgow, received her master's degrees in art history and paintings conservation from New York University, Institute of Fine Arts. Her master's thesis focused on the painting process and working methods of the Flemish painter Jacob Jordaens. She is currently working as a paintings conservator at Studio Redivivus, Den Haag. Her work focuses on the treatment of old master paintings and the use of material analysis and technical imaging to understand these artists' techniques.



# CONSERVATION OF ART IN PUBLIC SPACES (CAPUS) PROJECT AND ITS OUTCOMES

By Dr. Sagita Mirjam Sunara

*Conservation of Art in Public Spaces (CAPuS) was a three-and-a-half-year project devoted to the development of guidelines and protocols for the protection and conservation of contemporary public art and of education and training opportunities in that field. Funded by the European Commission through the Erasmus+ Knowledge Alliances Program, the project was jointly carried out by 17 partner institutions from five European countries: Italy, Spain, Croatia, Germany and Poland.*

The CAPuS project ended in June with a two-day online conference (4-5 June 2021) that featured presentations of the key results by members of the project partnership. The program also included talks by invited speakers, experts in the field of public art conservation (Lydia Beerkens, Marco Ciari, Francesca Modugno, Elena García Gayo, Rosa Gasol, Antonio Rava and Maria Chatzidakis). This article will focus on the presentations delivered by CAPuS team members and will provide an overview of the main outcomes of the project.

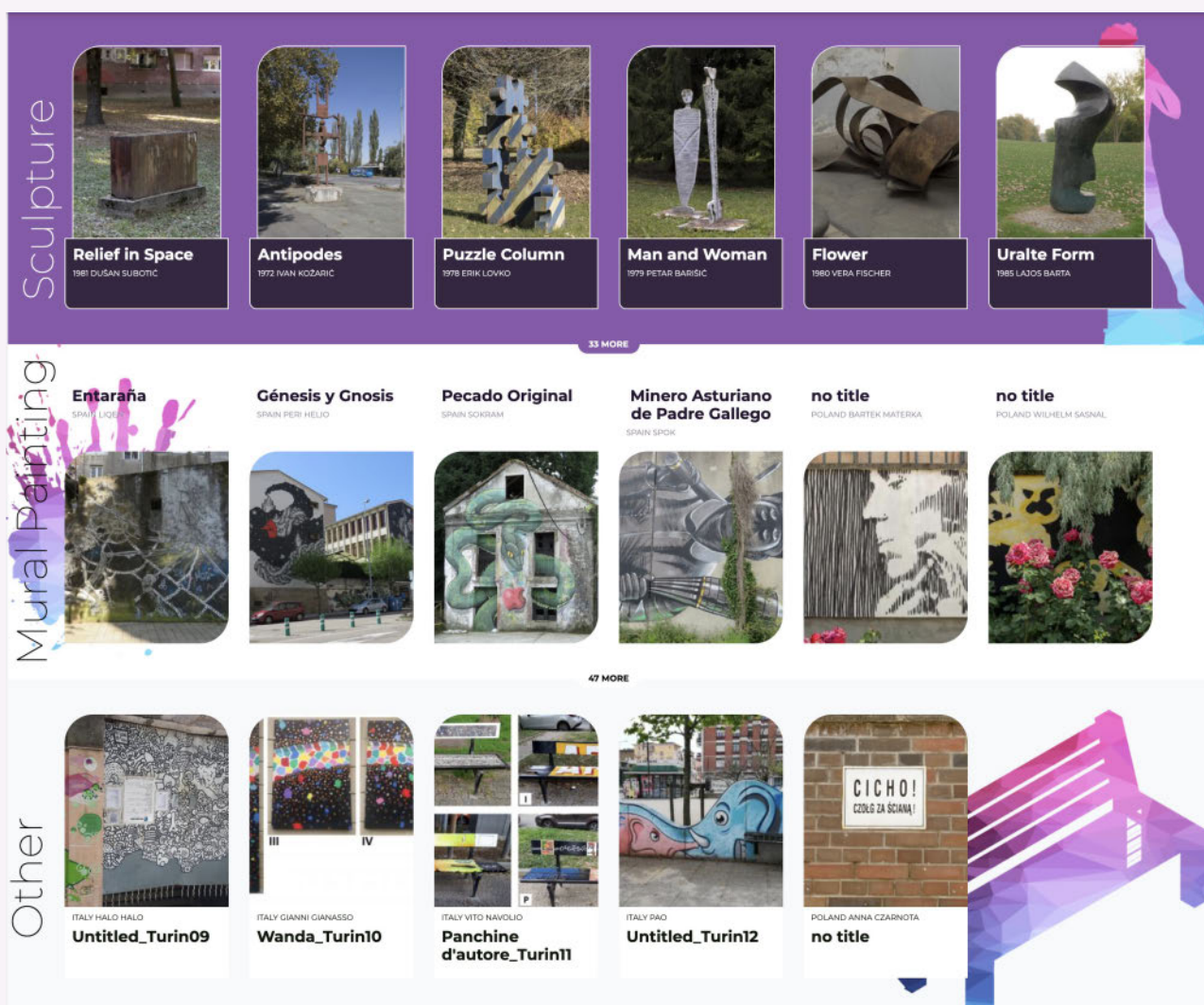

Top: Logo of the Conservation of Art in Public Spaces (CAPuS) project. Bottom: Screenshot of the front page of the CAPuS Digital Repository. Images courtesy of Sagita Mirjam Sunara.

In the conference's opening talk, project coordinator, Dominique Maria Scalarone (University of Turin), explained that the CAPuS project was driven by the need to tackle two issues: the lack of specific initiatives for the conservation of contemporary public art and the underrepresentation of the subject in university study programs. Higher education institutions, businesses/enterprises, research centres, cultural institutions, NGOs and public bodies came together to offer solutions. The partners broke the work into four stages. First, they selected a number of artworks (almost one hundred murals and sculptures) and thoroughly explored their socio-cultural context. Program partners then examined techniques, materials and condition of each artwork and tested products for specific conservation treatments. Next, they defined a conservation methodology for public works of art. In the final stage the team devised models for the transfer of the acquired knowledge and experience to students, educators and professional conservators.

During the project the CAPuS team collected and produced a wide range of information and documentation on the studied artworks. This documentation is openly and freely available through the CAPuS Digital Repository, which is available on the [CAPuS website](#) under Resources. In this online database, which was presented at the conference by the author of this text, each artwork has its own data sheet containing general information about the piece as well as technical and conservation documentation. This information serves as a basis for future conservation interventions on the studied artworks but can also be useful in the study and treatment of other pieces. Other scholars can use it to continue the research carried out by the CAPuS partnership. The repository can support teaching and learning and raise public awareness and understanding of public art. Its structure, functionality and content were presented in a three-part Zoom event series that took place in May, the recordings of which can be viewed [here](#).

José Santiago Pozo Antonio (University of Vigo) and Josipa Bilić (Metris Research Centre) discussed the technical study of the artworks that the CAPuS team worked on including the non-destructive and minimally invasive methods they used to examine the stratigraphy, analyse constituent materials and identify degradation products. An extensive report on this research is available on the [CAPuS website](#), under News > Project updates (this part of the website provides access to the final report of each work package).

A large part of the project effort was dedicated to identifying the products and methods that can be used for specific conservation treatments. The testing was performed on mock-ups, both outdoors and in a laboratory setting. Michela Berzioli (An.t.a.res srl) discussed the testing of products for consolidation, cleaning (dirt and overpaint removal) and surface protection of murals. Neven Peko (Sisak Municipal Museum) talked about research focused on finding the best method for the removal of aged coatings from

Sampling of the mural painting on the wall of Colletta Swimming Pool (various artists, 2011). Courtesy of the University of Turin and La Venaria Reale Conservation-Restoration Center.



CAPuS Methodology Workflow Diagram. Image courtesy of Centro per la Conservazione ed il Restauro dei Beni Culturali "La Venaria Reale" (as part of the CAPuS Project)



Testing of mock-ups at the Montana Colors Laboratory. Courtesy of Montana Colors.

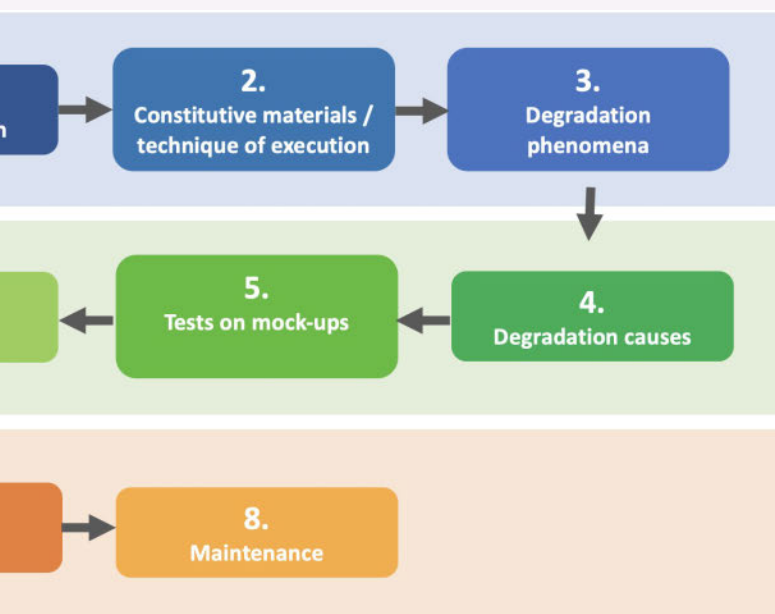

painted steel sculptures and identifying the most suitable coating system for their repainting.

During the CAPuS project, an [illustrated multi-lingual glossary](#) (English, Italian, Spanish, Croatian, German, Polish) was produced. The first part includes terms related to street art and graffiti, while the second part encompasses conservation terms. The glossary was presented by Paola Croveri (La Venaria Reale Conservation-Restoration Centre) and Marc Mascort i Boix (Montana Colors). They stressed that categorizing the complex and diverse subculture of street art and graffiti was extremely challenging as it required dealing with related jargon and because the terminology is constantly developing and growing. Terms that have a negative connotation in common language, and that could implicate a different and subjective attachment, were not included in the glossary. One such example is the term *vandalism*.

One of the main project outputs were the guidelines for conservation of public artworks. As Arianna Scarcella (La Venaria Reale Conservation-Restoration Centre) explained, the guidelines focus on two major issues: the study of the artwork in order to understand what needs to be conserved and why and the determination of suitable strategies for the preservation/conservation of the piece. The CAPuS workflow diagram includes eight steps. The guidelines provide an explanation of the objectives of each step and present the activities, results and reflections of the CAPuS team members related to that specific step. They also include practical questions and case studies. The guidelines do not offer ready-made solutions; the conservation approach and the practical intervention on the artwork must always be case-specific.

CAPuS partnership was keen on providing training opportunities for professionals wishing to specialize in public art conservation and on developing open and free educational resources for students and teachers. Ilaria Sacconi (CESMAR7) presented the webinar for professional conservators "Materials and Methods for Public Art Conservation. Strategies for contemporary murals", which took place in April 2021. Its recordings can be accessed [here](#). Monica Gulmini, Floriana Vindigni and Tina Lasala (University of Turin) presented the CAPuS [e-learning platform](#) which serves students and university teachers. The self-paced learning course is intended for master's degree students but can also be of interest to professionals who wish to expand their knowledge in this area. As for the educators, the platform provides materials and resources for teaching an entire course on public art conservation. One can, of course, include the whole course or select the units in what he/she already teaches.

Under the auspices of the CAPuS project, several master's—and one doctoral—thesis projects were carried out. Three projects were presented at the conference. In his inspiring talk, Enrique Manuel Alonso Villar (University of Vigo), who researched the deterioration of murals in



Screenshot from the documentary *Time Has Not Helped* showing the 1984 monumental relief *Door* by Branko Ružić in Sisak, and the daughter of the deceased artist, Rajka Zlatarić. Click to watch the film.

Galicia, Spain, provided an insight into the CAPuS project from the perspective of a doctoral student. Jelena Hudinčec (University of Split) discussed her art historical research related to the Sisak Steelworks Fine Artists' Colony, and Giulia Pellis (University of Turin) presented her research on the cleaning of street art and graffiti.

It is worth noting that an educational documentary was produced with the CAPuS project funds, *Time Has Not Helped* (authors: Sagita Mirjam Sunara, Dragan Đokić). The film discusses the scientific and practical research that must precede any conservation work on outdoor sculptures. The film can also be accessed both through the e-learning platform and through the Digital Repository.

I encourage the readers of *News in Conservation* to explore the CAPuS website, especially the Resources section. The CAPuS team members hope that the materials and research data they have openly shared will be used by conservation students, university teachers, professional conservators and even artists. We also hope that the work we have done will help advance the protection, preservation and appreciation of contemporary public art.



**Dr. Sagita Mirjam Sunara** is an associate professor at the Conservation Department of the Arts Academy, University of Split (Croatia) and vice-dean of Arts, Science, International Cooperation and ECTS credits. She has been teaching for over 15 years, including a semester as a visiting teaching fellow at the Winterthur/University of Delaware Program in Art Conservation (USA). Also while at the university, she worked at the Croatian Conservation Institute Section for Stone in Split for five years.

# CONTEXTUALIZING DECISION-MAKING MODELS IN CONTEMPORARY ART CONSERVATION

By Julia Betancor

*CAN! Conversations is a new discussion series on the quandaries of conserving contemporary art, launched by AIC's Contemporary Art Network (CAN!).*

In our first session, we wanted to explore how decision-making in conservation occurs in a variety of contexts, because much of the literature on decision-making in conservation implies that an artwork is typically owned by and located in a museum. In such institutional contexts, curators, conservators, and artists (or their estates) work with a sense of indefinite belonging, sometimes over long periods of time.

Conservators of contemporary art know, however, that such permanence is often not the case for many artworks in their care, for example when the artwork does not yet belong to a museum or when the artwork has not yet arrived at its presumably final destination. How does preservation and care decision-making work in these other contexts? Four conservators representing different countries—and working in a variety of situations including museums, kunsthallen, private collections, galleries or auction houses—discussed their environments and processes. Our hope is that our conversation will help normalize and acknowledge cases of divergence from traditional paradigms as well as highlight the complexities and opportunities that exist in these contexts.

Our conversation began with Joy Bloser who represented the most classic position as a conservator with experience from three different American museums. She reflected on the 1999 Decision-Making Model and its recently revised version in her practical experience.

Mirosław Wachowiak spoke about typical complexities for a conservator within the kunsthalle in Torun (Poland) where his scope of conservation care for art focuses solely on the time span of an exhibition, without knowledge of the work's history or its future. He often works directly with artists who are installing works never before exhibited. This experience suggests the need for implementing "conservator/artist cooperation" and "artist active presence" as crucial terms within professional conservation terminology as well as an acknowledgment of the need for compromise in treating objects, depending on the owner of the work and on the work itself (i.e. the history—or lack of history—of its display).

Julia Betancor provided the perspective of a private conservator working predominantly for an expanding private collection in Madrid, Spain. Her conservation considerations are focused mostly on incoming, complex artworks and their requirements for proper long-term care, which are not always acknowledged or followed. She spoke about two artworks with different issues, one by KAWS and the other by Izumi Kato, where the voices that determined the decision-making model for their conservation were

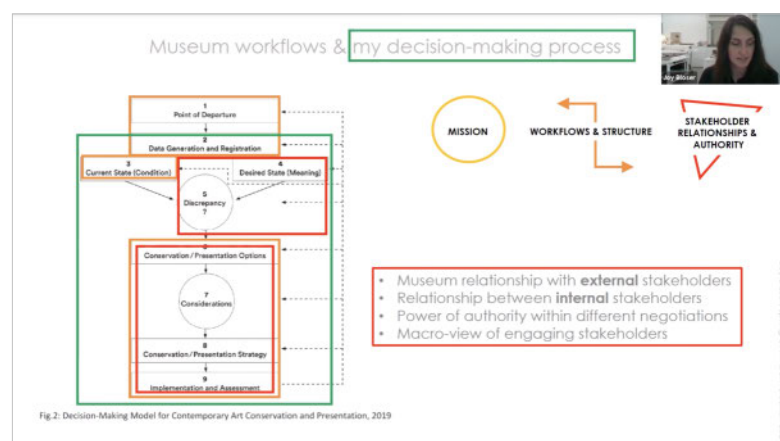

Top: The 1st CAN! Conversation panelists, TL to BR: Joy Bloser, Martha Singer, Mareike Opeña, Mirosław Wachowiak, Julia Betancor, and AIC/FAIC admin Ryan Winfield. Bottom: Decision-Making Model tree by Joy Bloser.

stakeholders from the art world—the art insurance company and the artist gallery—without taking into account the conservation department’s condition reports. Despite the efforts of the conservators, KAWS’s work remains pending conservation intervention. With Izumi Kato’s work, the gallery acted as an intermediary between the artist and the collection, suggesting the work be remade in Japan. Ultimately, the owner decided to keep the work in a state closer to the original, respecting its authenticity, since conservation would have meant creating a different piece.

Lastly, Mareike Opeña spoke about her experience of contextual conservation within the New York City art market where artworks come and go through private conservation studios at a fast pace. Here, various stakeholders are as influential in conservation decisions as the work’s materiality itself. Artistic, ideological, and monetary values are just a few factors that shape conservation expectations for every work entering the studio. Communicating and carefully navigating these expectations among invested stakeholders are important skills these conservators rely on in order to successfully treat the artwork.

The panel was moderated by Martha Singer who, with a hybrid position of working as a private conservator and in institutional settings around NYC, guided the conversation and moderated questions from the audience.

During this time there were open questions and interesting thoughts from some of the most respected practitioners in the field of contemporary art conservation:

- How to teach the decision making models to conservation students.
- Which would be the worst case: the artwork is pronounced "dead" or "total loss"?
- How do collectors arrive at this decision, and who has the authority to declare death?
- And in a sense ... how could an insurance company determine that the artwork has become a "total loss"?
- If the information from the artist is only distributed to a select few, it is a hindrance to the artwork’s preservation; is it worth the risk of interfering with the artist’s pursuit in the service of long-term preservation goals?

This first session in the CAN! Conversations series was well worth the exploration of these challenges in our profession, putting aside the shame and guilt for the sake of discussion. The main takeaways from the event are centered on the idea that we, as art conservators, should remind the contemporary art market and stakeholders that conservation decisions should be transdisciplinary. We should emphasize the importance of the holistic notion of the work of art at the point of purchase, and use the tool of conservation interviews as a model of solution between the different structures. We should also openly share artist interview models for professional research and exchange, which will only strengthen our collective knowledge.

Some words to highlight from our meeting are: honesty, roadmap, extreme flexibility, mistake sharing.

Our field of conservation has changed in recent years to recognize different constellations of people in different settings and at different times. Inevitably different decisions will be made, and that is part of the adaptation and validation of the decision-making model.

*A final note from Julia: We are grateful that Martha Singer proposed this open conversation, which was born from a doubt that she wrote in to the AIC / FAIC forum, asking for help—thank you for being such a gracious host. Working on this first CAN! Conversation has become one of the most memorable, rewarding and enriching experiences of my professional life. Once again I want to highlight the importance of belonging to professional associations (IIC, AIC, ICOM) and the value of sharing experiences, as this gives us security to feel that we are not alone in the face of the challenges that come with conserving contemporary art.*

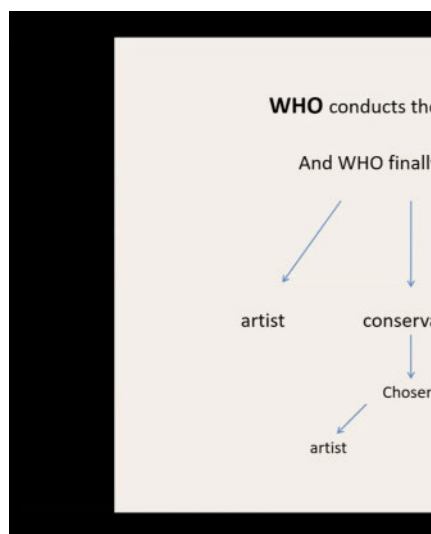
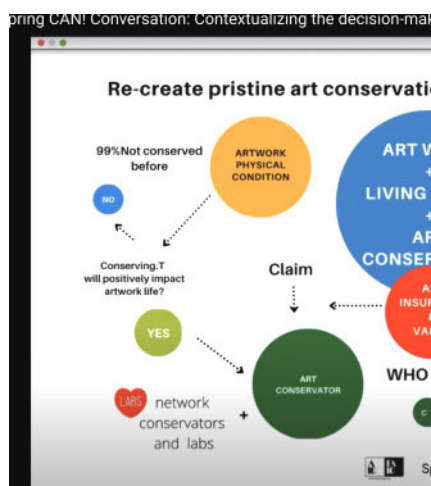
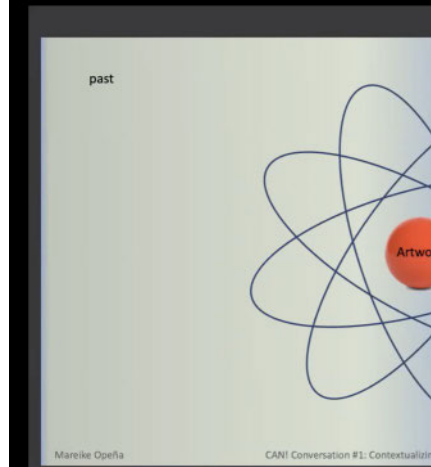

Top: Decision-Making Model tree by Mareike Opeña.

Center: Decision-Making Model tree by Julia Betancor.

Bottom: Decision-Making Model tree by Miroslaw Wachowiak.

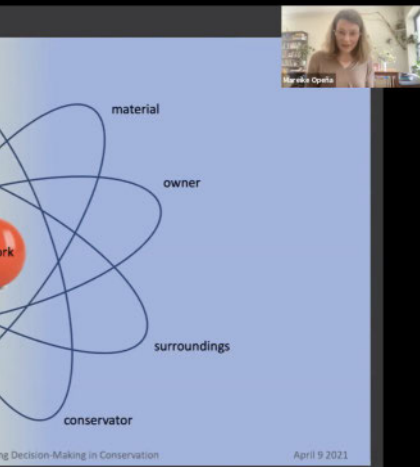

The CAN! Conversations panel is available online: <https://youtu.be/m2Hdcl6jppA>

Julia Betancor  
Associate Director Art Conservator. Colección SOLO. Spain

Joy Bloser  
Assistant Objects Conservator. The Menil Collection

Mirosław Wachowiak  
Associate Professor/Conservator Nicolaus Copernicus University/Centre of Contemporary Art, Toruń

Mareike Opeña  
Associate Conservator. Contemporary Conservation Ltd

Marta Singer  
Director of Material Whisperer Consultation and Conservation Services, New York.

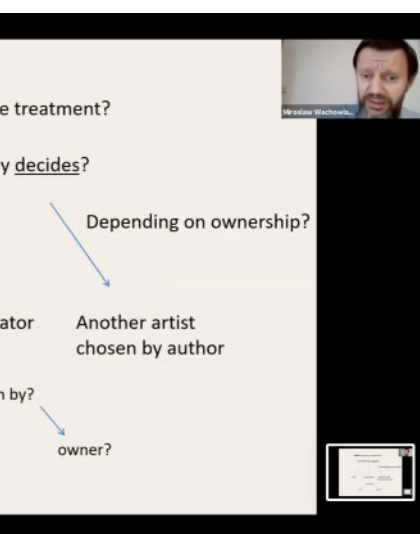
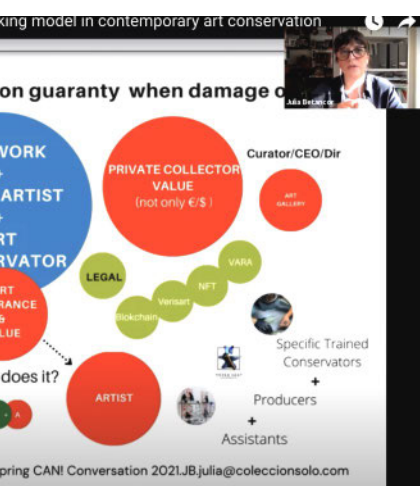

Click on the BONUS CONTENT link for access to additional readings on the topic, suggested by the author.



**Julia Betancor** is associate director art conservator for Colección SOLO, Spain. Since 1996 She has specializes in paintings and modern and contemporary art. Julia offers preventive conservation collection consultation and treatment services with a small international team in the context of the premium private art business industry. She is also a professor at the Nebrija University, Madrid.

# ORIGINALITY AND AUTHENTICITY: A REAL SOCRATIC DIALOGUE

By Ellie Sweetnam

*This particular Socratic dialogue, hosted by Bill Wei (RCE senior conservation scientist), was a continuation from the IIC November 2020 "Conservation and Philosophy Symposium: Intersections and Interactions", headed by the question: What is the difference between originality and authenticity?*

A Socratic dialogue is neither a debate nor a discussion. The format is such that it creates a space, free from intimidation, to discuss topics that may be considered controversial; it opens a dialogue to differing opinions and provides each participant an equal opportunity to speak. The aim is to understand what is behind the question being proposed and why participants disagree.

While there are a number of formats that the dialogue can take, this event was a short version called The Statement with the group separated into small (virtual) breakout rooms with around six participants in each. Having been presented with an initial question, participants were given ten minutes to create a one-and-a-half-minute statement on their personal opinion. After each presentation, participants were given thirty seconds to write a follow-up question for that presenter. This question must be open and informative, asked in the "You and I" form and could not be judgmental, opinionated, steering or closed. One could ask, for example, "What do you mean by this?" rather than "Why didn't you think that?". After each person asked a question, also allowing the presenter to respond, the group moved on to another round with a new or related question. After the dialogue had come to an end, each participant wrote what they felt to be the essence of this event and what they took away from the experience.

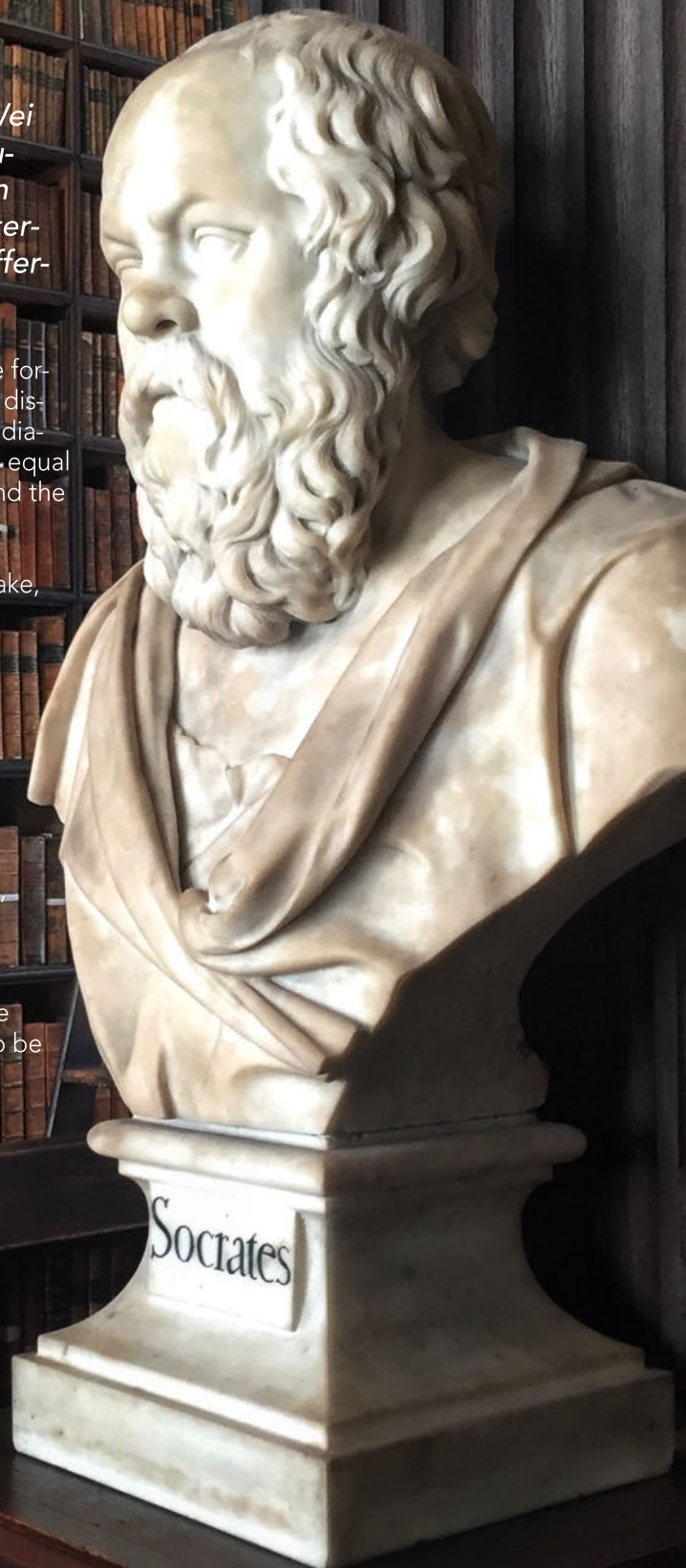



Socrates, image by Allan Henderson/Flickr (2016). Licensed under [CC BY 2.0](#). Original location [here](#).

*“One participant’s statement began with the concept of authentic cuisine and what it means to them to eat a meal within its geographical context—that being promised the ‘authentic’ experience outside of that always felt lacking in a certain sense.”*

The creation of this safe and free space requires active participation and discipline throughout the event from each individual, with the goal of listening to one another. The aim is to fully understand each presented perspective rather than to convince or persuade others of yours. It does take courage to present your thoughts for intense scrutiny; however, the capacity and format of the dialogue does not allow for there to be any judgement, intense interrogation, or for arguments to take place in which you need staunchly defend your ideas. In the case of my own group, most of the statements and the following dialogue stemmed from our own experiences and navigation from working in the sector rather than a researched baseline. One participant’s statement began with the concept of authentic cuisine and what it means to them to eat a meal within its geographical context—that being promised the “authentic” experience outside of that always felt lacking in a certain sense. However, the follow-up questions and resulting dialogue allowed for this initial discussion on cuisine to move to the nature of institutions and their own individual character. While every institution uses its own vocabulary, which can in some aspects give an object its own meaning, the original material context will always anchor it to its original context.

This format allowed our group to home in on specific areas of a perspective and then use introspection to explore our own biases and perceived narratives.

While our group may not have ended the session with an answer to the initial question, the Socratic dialogue allowed for the participants to experience and be guided through a unique model of communication, gaining an understanding into not only their own thought process and how to present these thoughts, but also into those of others. The constant mindfulness of language and experience within the setting of the dialogue means that you become more reflective and open in your approach to these multiple concepts within any future scenario.



**Ellie Sweetnam** came into conservation from an Arts background and has used her multiple skill sets to gain a broader skill base both in the academic field and practical conservation field. Her work utilises the concept of *cræft* to draw links between mends and treatments, which has been explored through the creation of Disruptive Conservation. She is now working for the IIC as fellowship and membership programme manager.

# ANNOUNCEMENTS

*Due to the rapidly evolving situation regarding Covid-19, many event details are changing. We are trying to update these listings as much as we can, but readers should contact event organizers directly for the most up-to-date information on specific events, conferences, workshops, etc. Thank you, from the IIC Communications Team.*

## CALLS FOR PAPERS

**AICCM Paintings SIG Virtual Forum: Australian-made**  
15 November-3 December 2021

Australia

Call for contributions

For further information please contact Raye Collins ([raye.collins@ngv.vic.gov.au](mailto:raye.collins@ngv.vic.gov.au)) or Raymonda Rajkowski ([raymonda.rajkowski@ngv.vic.gov.au](mailto:raymonda.rajkowski@ngv.vic.gov.au))

**ICOM-CC Working Group Graphic Documents, Interim Meeting**

10-13 February 2022

Online

Abstract deadline: 10 October 2021

For further information, please contact us at:

[icomccgraphdocs@aol.com](mailto:icomccgraphdocs@aol.com) or

[andrea.pataki@th-koeln.de](mailto:andrea.pataki@th-koeln.de)

**5<sup>th</sup> International Conference on Innovation in Art Research and Technology (InArt 2022)**

28 June-1 July 2022

Paris

Abstract deadline: 17 December 2021

Further information found here: <https://inart2022.sciencesconf.org/>

**15<sup>th</sup> ICOM-CC Wet Organic Archaeological Materials Conference (WOAM)**

19-23 September 2022

Kazan, Republic of Tatarstan

Call for papers deadline: 31 October 2021

Please submit abstracts for papers to [www.conference-service.com/ICOM-CC-WOAM2022](http://www.conference-service.com/ICOM-CC-WOAM2022) and follow the steps to create an account

## CONFERENCES, SYMPOSIUMS

**Watermarked Papers of the 1830-1950 Period**

8-9 October 2021

Paris, France

For more information visit: <https://www.iiconservation.org/content/conference-watermarked-papers-1830-1950-period>

**IIC-Student & Emerging Conservator Conference**

The Faces of Conservation

14-16 October 2021

Lisbon, Portugal / Online

For more information visit: <https://www.iiconservation.org/content/save-date-iic-secc-2021>

**ICRI Conference: Celebrating 30 Years of Conservation in Ireland**

Challenges in Conservation: Past, Present and Future

14 October 2021

Online

Register here: <https://www.eventbrite.ie/e/icri-conservation-activities-in-ireland-vii-2-day-event-tickets-170054735291>

**Bienal Ibérica de património Cultural: Jovens e Património**

**AR&PA Ibarian Biennial of Cultural Heritage**

14-17 October 2021

Leiria

For more information visit: <https://www.bienalarpa.pt/bienal-arpa-2021>

**Icon Bath 2021 Conference: Ceramics, Glass and Stained Glass**

16-17 October 2021

Bath, UK

For more information visit: <https://www.iiconservation.org/content/icon-bath-2021-conference-ceramics-glass-and-stained-glass>

**2021 Safety and Cultural Heritage Virtual Summit: Preserving our Heritage and Protecting Our Health**

19-21 October 2021

Online / Washington DC, USA

For more information visit: <https://www.iiconservation.org/content/2021-safety-and-cultural-heritage-virtual-summit-preserving-our-heritage-and-protecting-our>

**International Conference-Curation and Conservation: Dress and Textiles in Museums**

21-22 October 2021

Turin, Italy

For more information visit: <https://dresshistorians.org/cfp-turin-2020/>

**17<sup>th</sup> International Conference of Conservation-Restoration Studies (Zagreb 2021)**

21-22 October 2021

Online / Zagreb

For more information visit: <http://www.konferencija-restauracija.com/en/conference.html>

**NKF XXII Kongress: IIC Nordic Group 22<sup>nd</sup> Triennial Congress**

21-22 October 2021

Stockholm

For more information and to register go to: <http://www.konservering.org/>**CAC Emerging Conservators Symposium**

23 October 2021

Online

For more information visit: <https://www.eventbrite.ca/e/ecc-symposium-tickets-161518398879>**Preservation Beyond Politics**

25-29 October 2021

Washington DC, USA

For more information visit: <https://www.eventscribe.net/2021/APTDC/>**13<sup>th</sup> North American Textile Conservation Conference: Outside Influences**

25-30 October 2021

Virtual / USA

For more information visit: <https://natconference.com/conferences>**TechFocus IV: Caring for 3D-printed Art**

25-30 October 2021

Online / USA

For more information visit: <https://resources.culturalheritage.org/techfocus/>**2021 Icon Annual Lecture: Captain Sir John Franklin's 1845 'lost expedition'**

27 October 2021

Online

For more details and booking: <https://www.icon.org.uk/events/icon-annual-lecture-2021.html>**6<sup>th</sup> International Virtual Meeting on Retouching of Cultural Heritage (RECH6)**

4-5 November 2021

Online (Spain)

For more information visit: <http://rechgroup.pt/rech6.html>**Western Association for Art Conservation Annual Meeting (WAAC)**

4-6 November 2021

Virtual (Zoom)

For more information visit: <https://www.waac-us.org/2021fallgathering>**Virtual Experiments for Wooden Artwork (VirtEx)**

5-6 November 2021

Online Colloquium / Dresden

For more information visit: <https://www.iiconservation.org/content/online-colloquium-virtual-experiments-wooden-artwork-virtex>**Symposium on the production, use and conservation of sheet glass**

5-6 November 2021

Romont, Switzerland

For more information: <https://vitrocentre.ch/en/art-history/conferences/international-conference.html>**Future Talks 021—the digital one—SMART SOLUTIONS IN THE CONSERVATION OF THE MODERN**

8-10 November 2021

Online

For more information visit: <https://dnstmd.de/en/future-talks-021/>**APOYOnline Conference: Connect, Empower, Transform: A Virtual Conference for Students and Emerging Professionals in Cultural Heritage**

12-15 November 2021

Online

For more information visit: [https://apoyonline.org/en\\_US/2021/08/07/call-for-papers-4th-regional-conference/](https://apoyonline.org/en_US/2021/08/07/call-for-papers-4th-regional-conference/)**Midwest Regional Conservation Guild Conference**

12-15 November 2021

Indianapolis, Indiana (USA)

For more information visit: <https://www.iiconservation.org/content/midwest-regional-conservation-guild-conference>**Eastern Analytical Symposium & Exposition**

15-17 November 2021

Plainsboro, NJ, USA

For more information visit: <https://eas.org/2021/?p=2155>**Knocking on Wood: Materiali e metodi per la conservazione delle opera in legno**

19-20 November 2021

Venaria Reale, Italy

For more information visit: [www.cesmar7.org](http://www.cesmar7.org) or write [cesmar7@gmail.com](mailto:cesmar7@gmail.com)**Contemporary Art Conservation Revisited: 20 Years Later**

25-26 November 2021

Online event / Bern

For more information write to: [mmm@hkb.bfh.ch](mailto:mmm@hkb.bfh.ch)**BAPCR Christmas Talk****Inpainting by algorithm: The conservator-restorer in the age of artificial intelligence**

26 November 2021

London

Email Gemma Collins at: [BAPCRsecretary@gmail.com](mailto:BAPCRsecretary@gmail.com)**Collection Care: new challenges in preventive conservation, predictive analysis and environmental monitoring**

1-3 December 2021

Valencia, Spain

For more information visit: <https://www.collectioncare.eu/conference>

**IADA 2022: Show it and Save it—before, during and after Covid 19: Exploring the Compromises between Exhibition and Preservation**

14-18 February 2022

Online / Germany

For more information visit: <https://iada-home.org/events/show-it-and-save-it-before-during-and-after-covid-19-exploring-the-compromises-between-exhibition-and-preservation/>

**SHAKE in Conservation Talks: Big Research in Tiny Speeches**

17 February 2022

Brussels, Belgium

For more information visit: [www.shakeinconservation.be/conservation-talks-2021](http://www.shakeinconservation.be/conservation-talks-2021)

**110<sup>th</sup> CAA Conference: Conserving Performance, Performing Conservation**

3-5 March 2022

Chicago, USA

For more information visit: <https://www.iiconservation.org/content/110th-caa-conference-conserving-performance-performing-conservation>

**50<sup>th</sup> AIC Annual Meeting: Reflecting on the Past—Imagining the Future**

13-18 May 2022

Los Angeles, USA

For more information visit: <https://www.culturalheritage.org/events/annual-meeting/current-meeting>

**Terra 2022 13<sup>th</sup> World Congress on Earthen Architectural Heritage**

7-10 June 2022

Santa Fe, New Mexico, USA

For more information visit: <https://na.eventscloud.com/website/8033/>

**IIC Wellington Congress 2022**

5-9 September 2022

Wellington, Aotearoa New Zealand (and Online)

For more information visit: <https://www.iiconservation.org/content/call-abstracts-iic-wellington-congress-2022>

**Metal 2022**

5-9 September 2022

Helsinki, Finland

For more information visit: <https://metal2022.paper-flow.com/default.aspx?ReturnUrl=%2f> or contact: [admin.metal2022@paper-flow.com](mailto:admin.metal2022@paper-flow.com)

**2022 ICOM-CC Glass & Ceramics Interim Meeting Recent Advances in Glass and Ceramics Conservation**

9-11 November 2022

Lisbon, Portugal / Online

For more information visit: [https://eventos.fct.unl.pt/icomcc\\_gc\\_2022](https://eventos.fct.unl.pt/icomcc_gc_2022)

**COURSES, WORKSHOPS**

**Webinar: Introduction to HVAC Systems (Image Permanence Institute)**

14 October 2021

Online

Register at: [https://rit.zoom.us/webinar/register/3216318015563/WN\\_6MLTvVlaTKCyURXkBN5rIA](https://rit.zoom.us/webinar/register/3216318015563/WN_6MLTvVlaTKCyURXkBN5rIA)

**Virtual Workshop—Beyond the Walls: Identifying decision making during disasters**

21 October 2021

Online / AICCM

More information here: <https://aiccm.org.au/events/beyond-the-walls-identifying-decision-makers-during-disasters/>

**20|21 Conservação e Restauro de Arte Contemporânea Masterclass—The artist's interview workshop**

28-29 October 2021

Porto, Portugal

For more information visit: <https://www.iiconservation.org/content/21st-masterclass-artists-interview-workshop>

**Indonesian Conservation Theory for Cultural Heritage-Workshop**

2-4 November 2021

Danube University Krems, Austria

For more information visit [HERE](#).

**Modern Art: Who Shares? (SBMK)**

4, 11 and 18 November 2021

Online

For more information visit: <https://www.sbmkn.nl/activiteiten/de-maand-van-de-kennisborging-nov2021>

**Icon Ceramics and Glass Group Online Lecture: Stain Reduction**

11 November 2021

Online

For more information visit: <https://www.icon.org.uk/events/ceramics-and-glass-group-stain-reduction-of-ceramics.html>

**Eastern Analytical Symposium & Exposition**

**In-person short courses (over 30 to choose from)**

14-17 November 2021

Plainsboro, NJ, USA

For more information visit: [https://eas.org/2021/?page\\_id=5072](https://eas.org/2021/?page_id=5072)

**Prevent: Mitigating Fire Risk for Heritage**

15-19 November 2021

Online Course

For more information please visit: <https://www.iccrom.org/it/node/3016>

20|21 Conservação e Restauro de Arte Contemporânea  
Masterclass—Agar Spray: New applications of rigid gel  
29-30 November 2021

Porto, Portugal

For more information visit: <https://www.iiconservation.org/content/20th-masterclass-agar-spray-new-applications-rigid-gel-treatment-large-surfaces-0>

20|21 Conservação e Restauro de Arte Contemporânea  
Masterclass—Agar Spray: New applications of rigid gel  
2-3 December 2021

Porto, Portugal

For more information visit: <https://www.iiconservation.org/content/20th-masterclass-agar-spray-new-applications-rigid-gel-treatment-large-surfaces-0>

Digital Teaching Workshop on Minimal Invasive  
Methods for the Conservation of Textile Painting  
Supports

1 March-1 April 2022

Online / Germany

For more information visit: [https://www.th-koeln.de/en/cultural-sciences/fusion-1-mare-nostrum-digital-teaching-workshop\\_85653.php](https://www.th-koeln.de/en/cultural-sciences/fusion-1-mare-nostrum-digital-teaching-workshop_85653.php)

Workshop on Asian Papers and Their Applications in  
Paper Conservation

2022 (tentative)

The British Library, London, UK

For more information visit: <https://www.minahsong.com/workshop>



Do you have a cultural heritage  
preservation event, conference,  
workshop, webinar, etc. that you would  
like to post on IIC social media and in  
“News in Conservation”?

Send the announcement to  
[news@iiconservation.org](mailto:news@iiconservation.org)



# NEWS IN CONSERVATION

INTERNATIONAL INSTITUTE FOR CONSERVATION OF HISTORIC AND ARTISTIC WORKS



INTERNATIONAL INSTITUTE  
FOR CONSERVATION OF  
HISTORIC AND ARTISTIC WORKS



@iic\_



@iiconservation



@International.Institute.for.Conservation



International-institute-for-conservation-  
of-historic-and-artistic-work-the

**IIC, 3 Birdcage Walk, Westminster, London SW1H 9JJ. Email: [iic@iiconservation.org](mailto:iic@iiconservation.org) [www.iiconservation.org](http://www.iiconservation.org)**

The International Institute for Conservation of Historic and Artistic Works (IIC) is a learned society, a registered charity and a company limited by guarantee with no share capital. Charity No. 209677. Company No. 481522.